













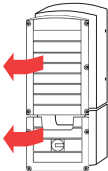

Three Phase Inverter with SetApp Configuration

PN: SEXXK-AUXIXXXXX

Quick Installation Guide

For Australia
Version 1.1

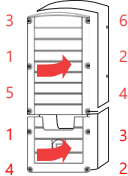
Legend

<p> NOTE</p> <p>This symbol denotes information intended to assist the user in making optimum use of the product.</p>	<p>Do not cut cable connectors</p> 	<ol style="list-style-type: none"> 1. Turn ON/OFF/P Switch to OFF (0) 2. Turn Safety Switch to OFF 3. Open cover screws 
<p> CAUTION!</p> <p>Denotes a hazard. It calls attention to a procedure that, if not correctly performed or adhered to, could result in damage or destruction of the product. Do not proceed beyond a caution sign until the indicated conditions are fully understood and met.</p>	<p>Inverter ON/OFF Switch: 0=OFF; 1=ON; P=Pairing/Program</p> 	
	<p>Turn ON/OFF the main circuit board AC switch, and wait 5 minutes</p> 	<p> This symbol appears at grounding points on the SolarEdge manuals and equipment.</p>
<p> WARNING!</p> <p>Denotes a hazard. It calls attention to a procedure that, if not correctly performed or adhered to, could result in injury or loss of life. Do not proceed beyond a warning note until the indicated conditions are fully understood and met.</p>	<p>Safety Switch (on optional DC Safety Unit)</p> 	<p>  9.0 N*m / 6.6 ft.*lb 10.3 N*m / 7.6 ft.*lb (Plastic)</p> <p>Fasten screws in described order</p> 
<p>Torque value </p>	<p>LEDs </p>	

Step 1

Installing the Power Optimizers

Verify string design with Designer

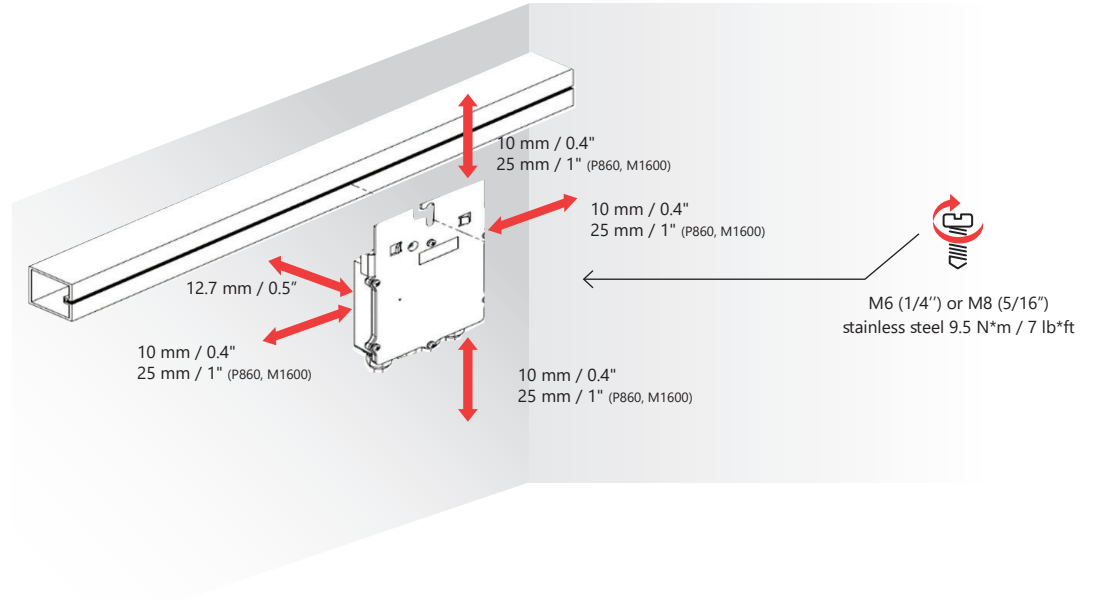

Step 1

1 2 3 4 5



Step 1

3

Input from module

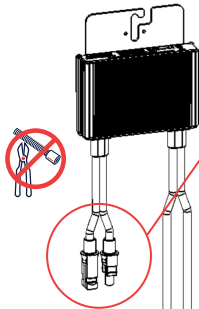

4

Output to string

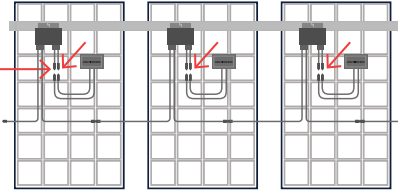
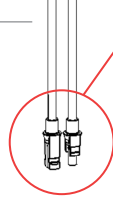

Extension cables (4mm²/1.6"²) between optimizers are allowed between rows and around obstacles

2:1 series connection

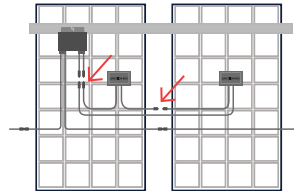

...

Use a dual input optimizer (P800p) for parallel connection of two PVs. Use a branch cable to connect two PVs to a single input optimizer.

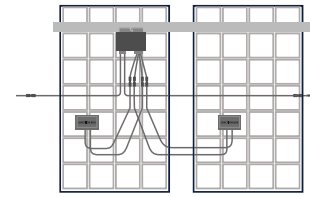

Step 1

1 2 3 4 5

Check string polarity and measure each string's voltage to verify $1 \pm 0.1V$ per optimizer

Example: 8 optimizers = ~8V

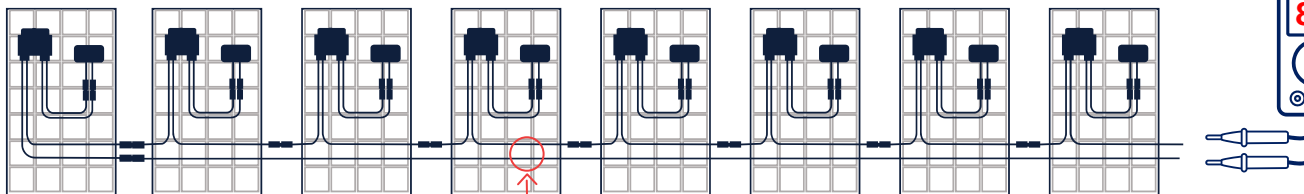
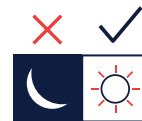

To minimize electromagnetic interference (EMI), make sure to minimize the distance between the positive and negative DC cables



20 cm / 8" where annual average high temperature is above 25°C / 77°F

On mesh fence

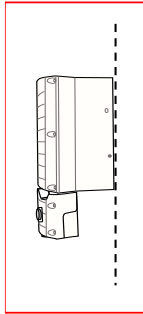

On mesh fence

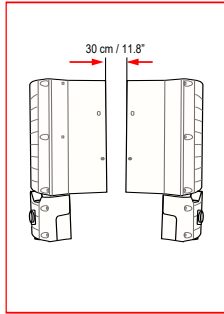

Indoor

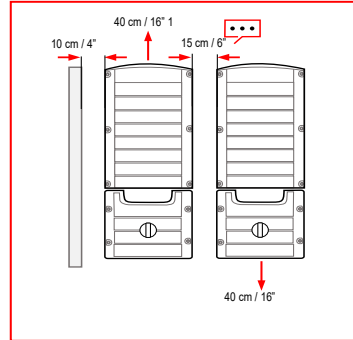

Outdoor

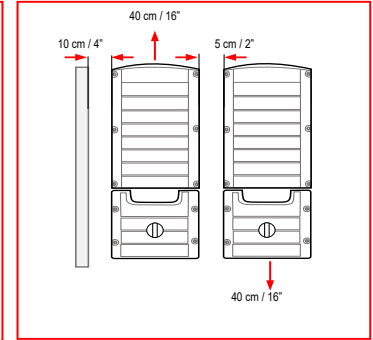

On metal back sheet

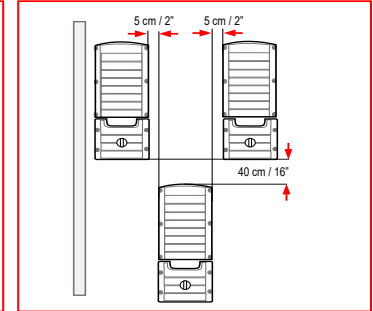
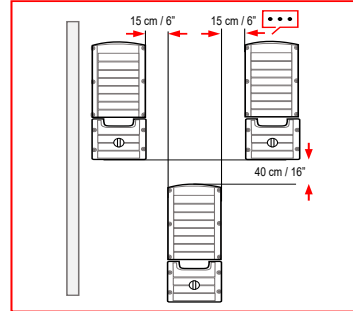
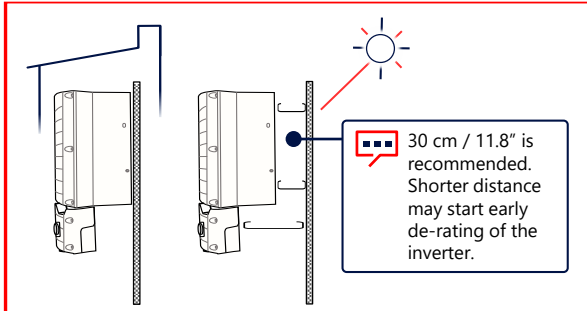

Step 2

1

2

2.1

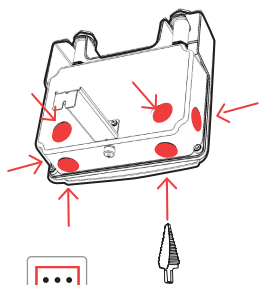

Use 3/4" or 1" Unibit drill to create holes for AC and DC conduits

2.2

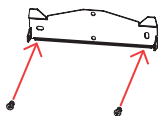

2.3

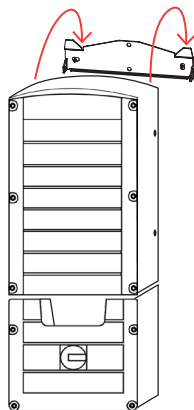

2.4

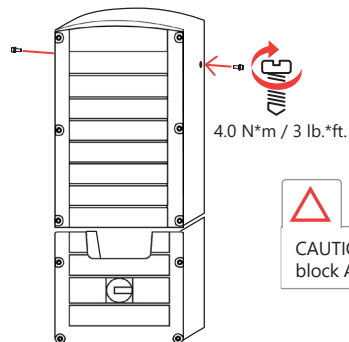

CAUTION! Do not block Airflow

2.5



Step 3

Connecting the PV Array

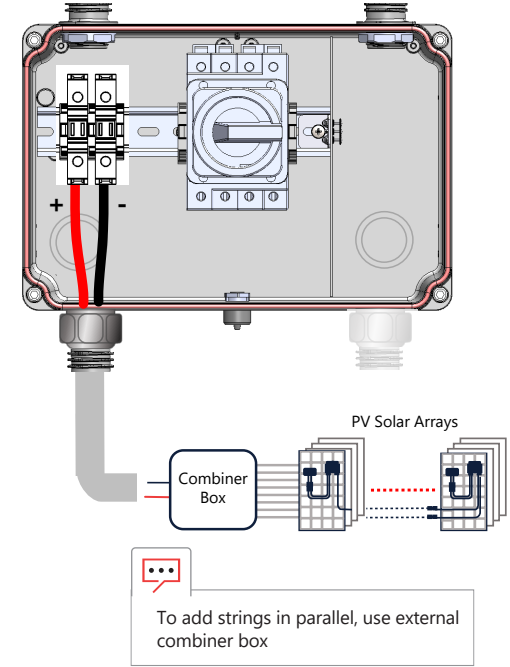
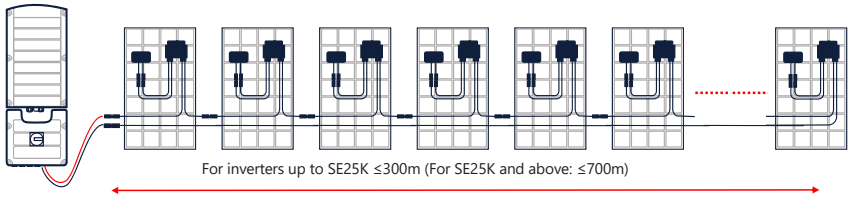
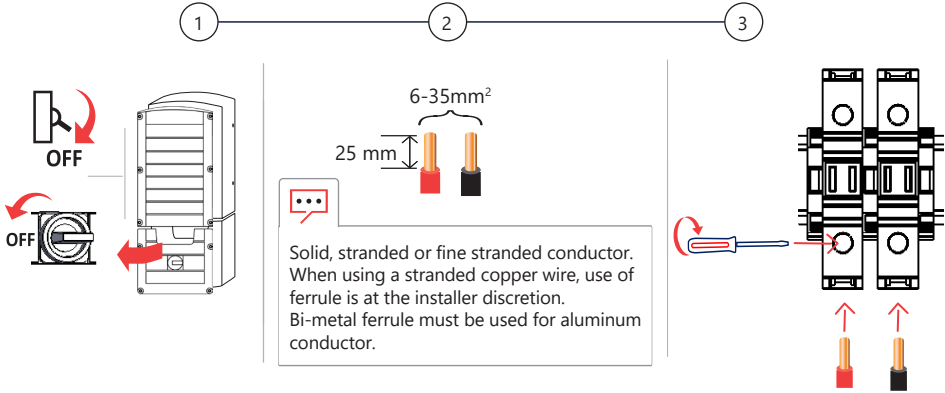

Step

4

Connecting to the AC Grid

1 2 3

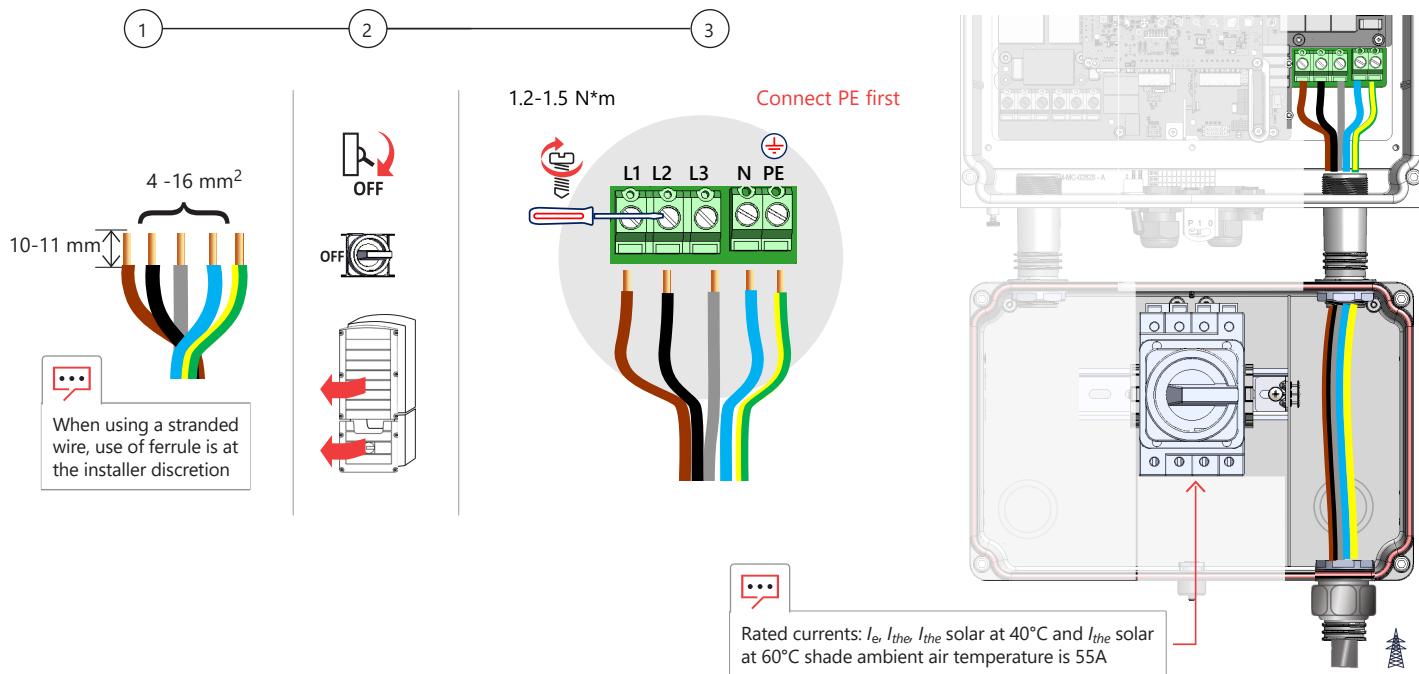

Step



5

Setting up Communication



Built-in:

1. Ethernet (see page 11)
2. RS485 (see page 11)

Optional												
	<table><tr><td>EN</td><td>Wi-Fi (Requires antenna)</td></tr><tr><td>FR</td><td>Wi-Fi (L'antenne est nécessaire)</td></tr><tr><td>NL</td><td>Wi-Fi (Antenne is vereist)</td></tr><tr><td>IT</td><td>Wi-Fi (È necessaria l'antenna)</td></tr><tr><td>DE</td><td>Wi-Fi (Antenne wird benötigt)</td></tr></table>	EN	Wi-Fi (Requires antenna)	FR	Wi-Fi (L'antenne est nécessaire)	NL	Wi-Fi (Antenne is vereist)	IT	Wi-Fi (È necessaria l'antenna)	DE	Wi-Fi (Antenne wird benötigt)	
EN	Wi-Fi (Requires antenna)											
FR	Wi-Fi (L'antenne est nécessaire)											
NL	Wi-Fi (Antenne is vereist)											
IT	Wi-Fi (È necessaria l'antenna)											
DE	Wi-Fi (Antenne wird benötigt)											

Step 5

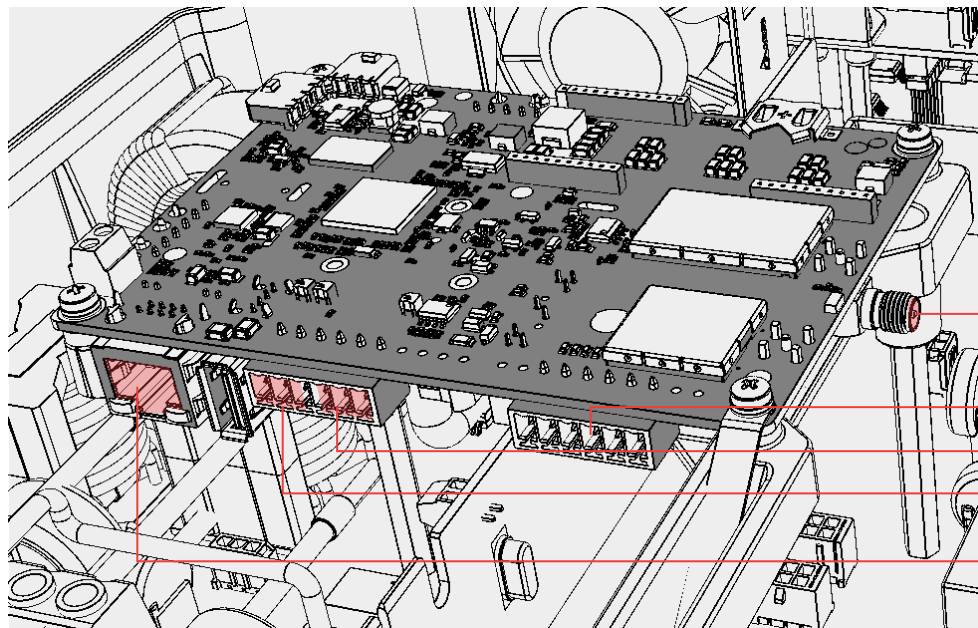

→ Wi-Fi antenna

→ PRI Control

→ RS485-2

→ RS485-1

→ Ethernet

Scan QR for troubleshooting



Scan QR for communication options



Step 6

Creating Ethernet (LAN) Connection

- 1
- 2
- 3
- 4

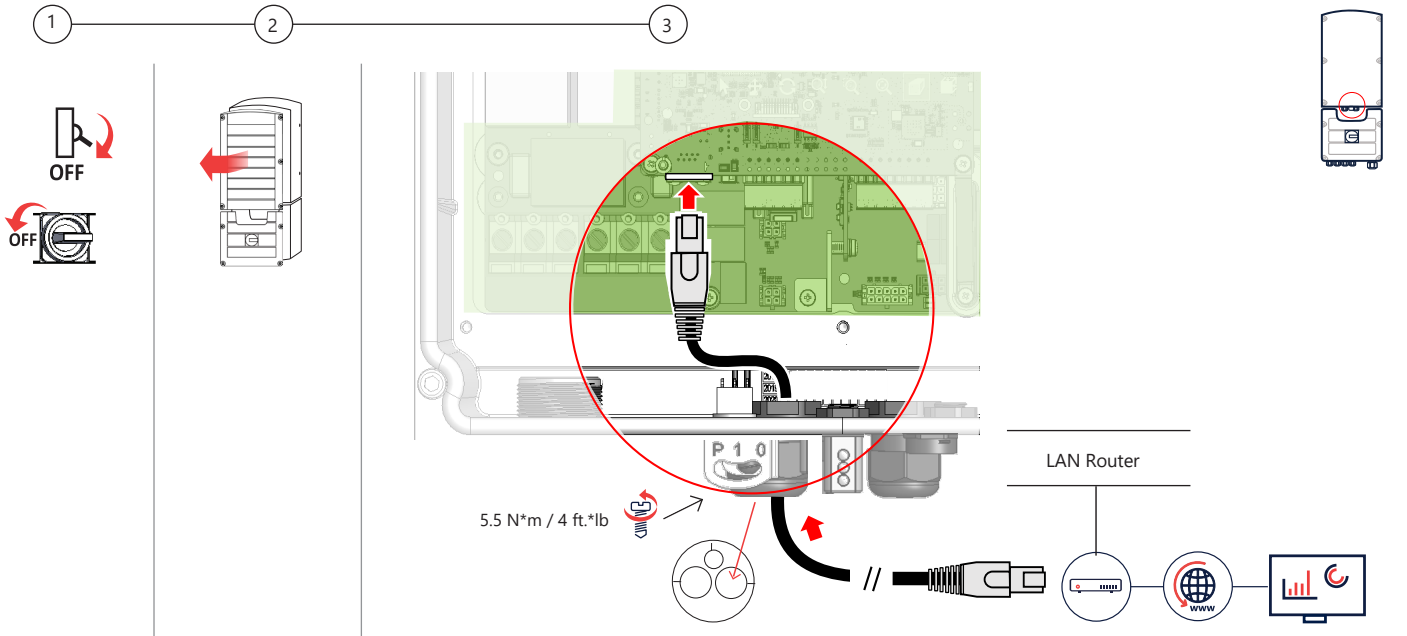

Step 6

1 2 3 4



RJ45 Pin #	Wire Color ¹		10Base-T Signal
	T568B	T568A	100Base-TX Signal
1	White/Orange	White/Green	Transmit+
2	Orange	Green	Transmit-
3	White/Green	White/Orange	Receive+
4	Blue	Blue	Reserved
5	White/Blue	White/Blue	Reserved
6	Green	Orange	Receive-
7	White/Brown	White/Brown	Reserved
8	Brown	Brown	Reserved

¹ The inverter connection does not support RX/TX polarity change.
Supporting crossover Ethernet cables depends on the switch capabilities

Step

7

Creating RS485 Bus Connection

- 1
- 2
- 3
- 4

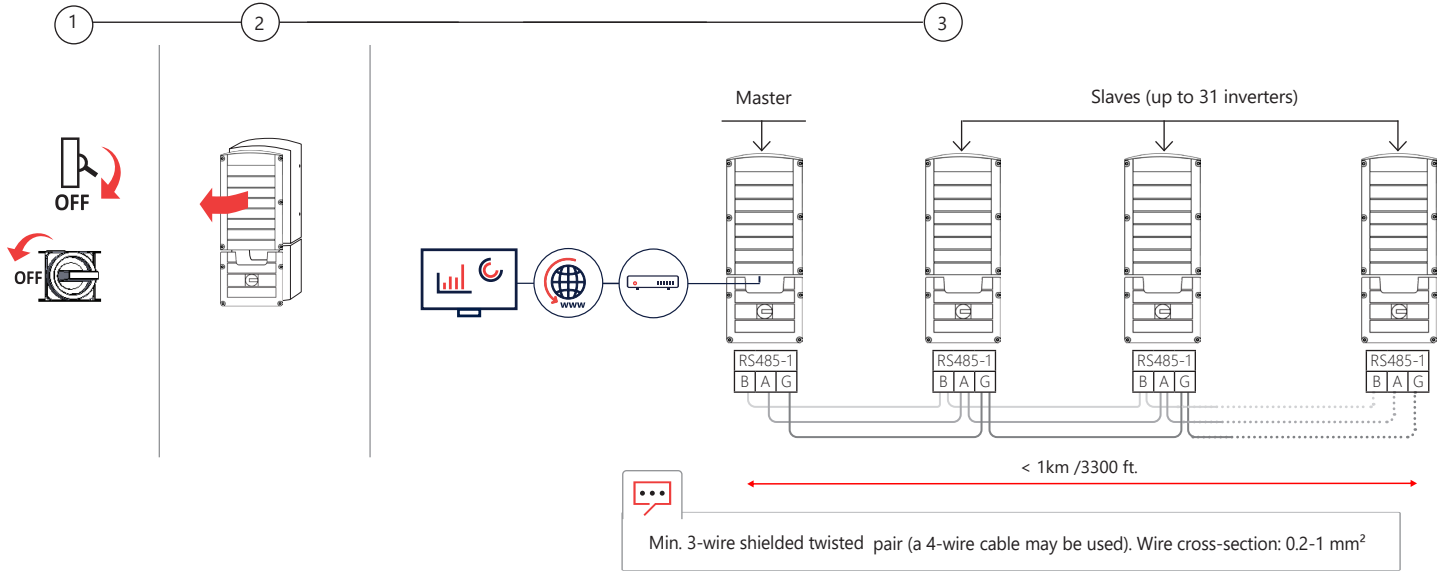

Step 7

1 2 3 4

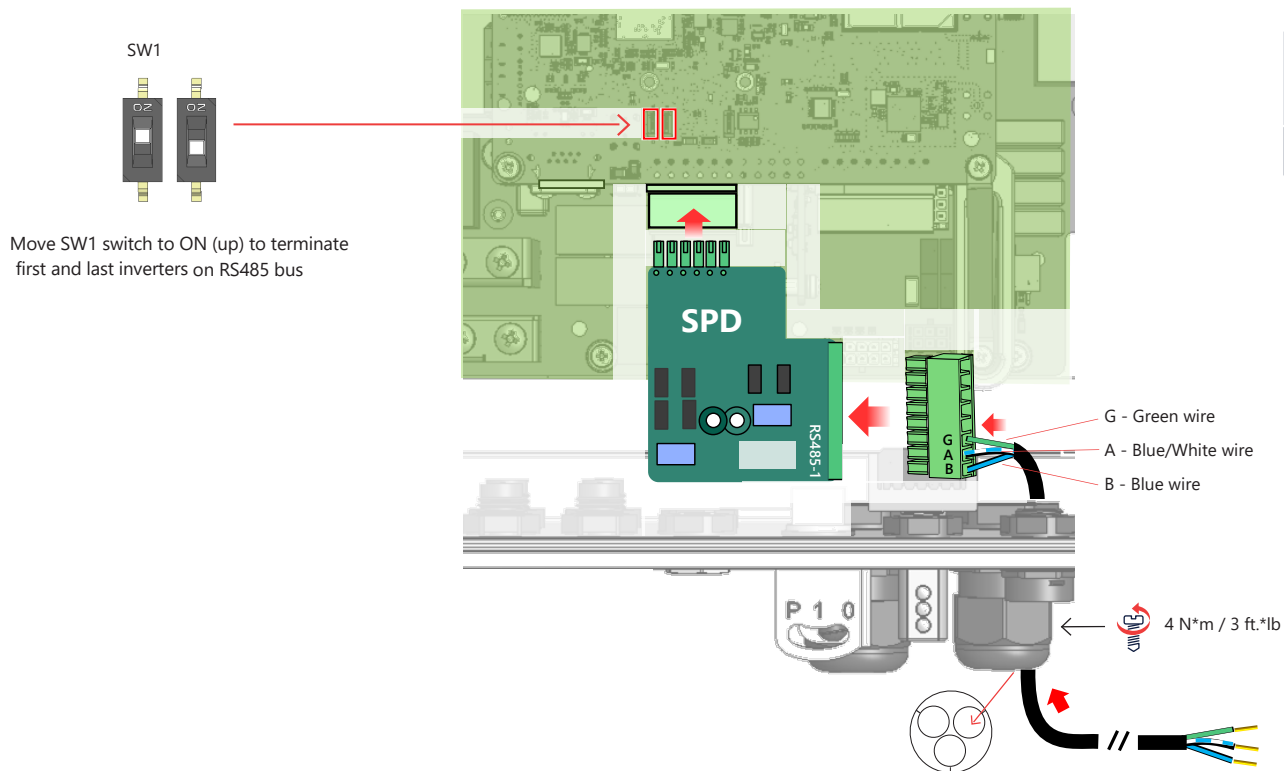

1



2

**Login:**

1. Open SetApp and follow the instructions
2. Log-in with your monitoring Username and password

Step
9

Activating

1 2 3



1

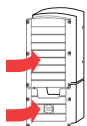

ON



ON

2



Scan inverter QR code; for RS485 bus, scan master first

3



Follow the SetApp instructions



SetApp creates a Wi-Fi connection with the inverter

Step 10

Commissioning



Set Country and Language

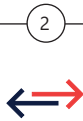

Set communication to the monitoring platform and to the other inverters



Set all other parameters



From the Commissioning menu, select Pairing to pair the optimizers with the inverter

Step 11

Viewing System Status

SetApp Status screen

solar edge		
Status		
Inverter SN 07318000C		
Power XX kW	Voltage XXX Vac	Frequency XX Hz
Optimizers Connected P_OK 30 of 30	Communication S_OK Ethernet	
Status Production	Switch ON	
Cos Phi 1.00	Limit No Limit	Country Australia
Voltage XXX Vdc	Temperature XXF	Fan OK

Monitoring platform

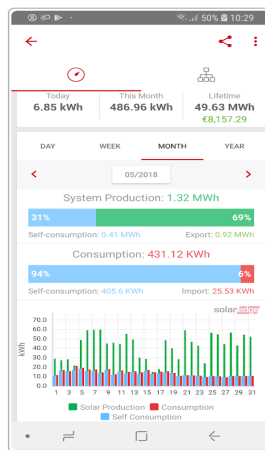

Main LEDs Indications

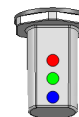



Support Contact Information

If you have technical problems concerning SolarEdge products, please contact us:

<https://www.solaredge.com/service/support>

Subject to change without notice.

Copyright © SolarEdge Inc.

All rights reserved. February 2022.



MAN-01-00695-1.1