

# IQ System Controller 3 INT

## Quick Install Guide



Scan the QR  
code for the  
latest Install  
guide

MODEL NUMBER-  
SC100G-M230ROW

VERSION 6.0  
MAY 2023



140-00273-06

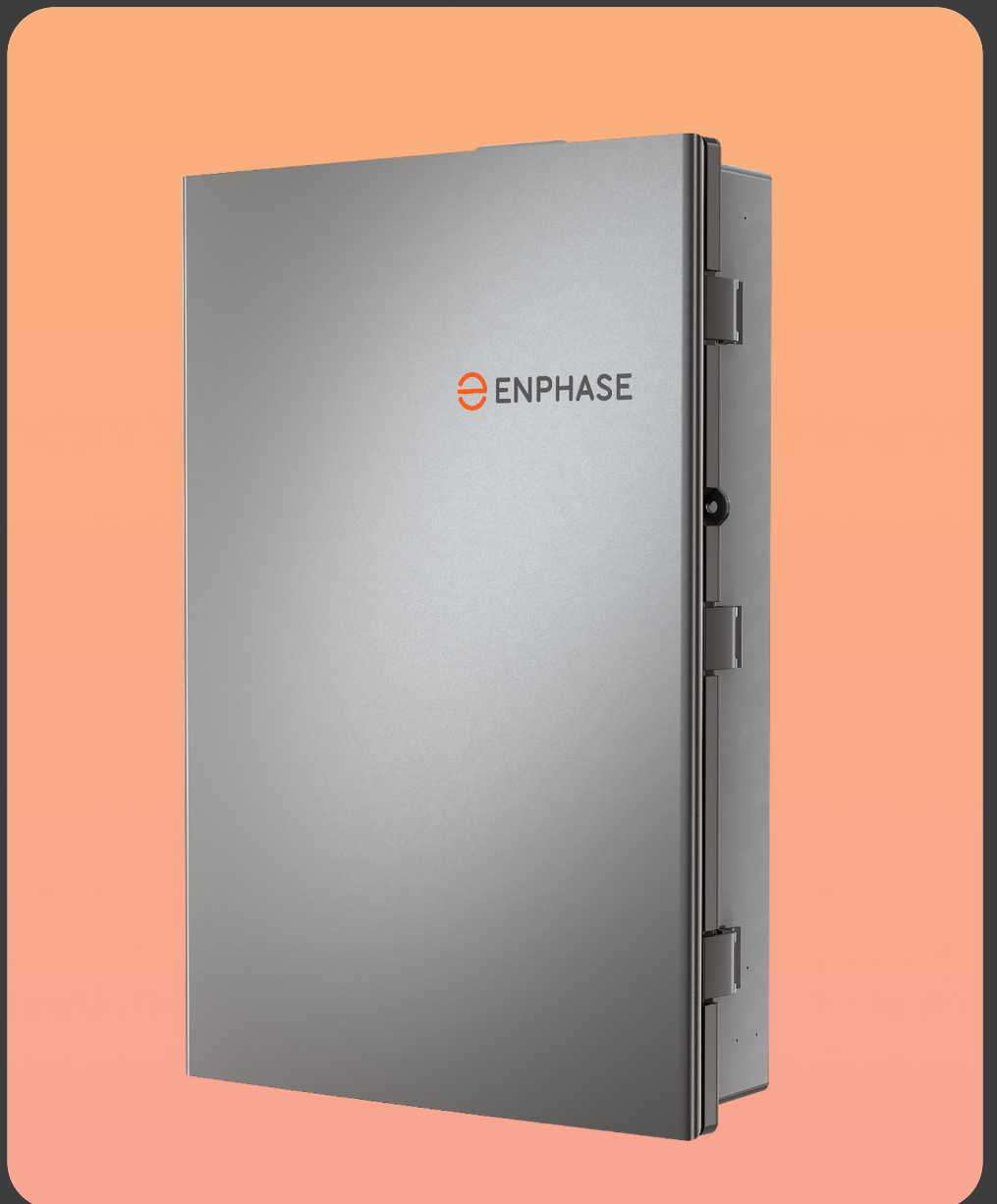

# Table of contents

## Introduction

### Section A

#### Mounting an IQ System Controller 3 INT

Tools/additional items required

Step 1: Plan a location for mounting the unit

Step 2: Minimum clearance

Step 3: Opening the door

Step 4: Mounting the IQ System Controller 3 INT

Step 5: Opening the dead front

### Section B - Wiring

Internal view of IQ System Controller 3 INT

Power terminals

Recommended breaker selection

Drill conduits

#### Single-phase home

Field wiring of mains

Field wiring of loads

Field wiring one branch of single-phase PV

Field wiring single-phase battery and one branch of single-phase PV

Field wiring two branches of single-phase PV

Field wiring two branches of single-phase PV and single-phase IQ

Battery

System field wiring single-phase battery and one branch of single-phase PV

#### Three-phase home

Field wiring of mains

Field wiring of loads

Field wiring three-phase PV

Field wiring three-phase PV and three-phase IQ Battery

Wiring control (CTRL) cable to headers

Control (CTRL) wiring between system components

Close dead front and install breaker filler plate

Connecting Cellular modem

System Shutdown (SSD) switch wiring

Energize IQ System Controller 3 INT

Safety

Revision history

# Introduction

The IQ System Controller 3 INT connects the home to grid power, the IQ Battery storage system, and solar PV. It provides microgrid interconnection device (MID) functionality by automatically detecting and seamlessly transitioning the home energy system from grid power to backup power in the event of a grid failure. It consolidates interconnection equipment and a communication gateway into a single enclosure and streamlines the grid independent capabilities of PV and storage installations by providing a consistent, pre-wired solution.

The IQ System Controller 3 INT supports IQ8, IQ7, and S Series Microinverters.

To install the IQ System Controller 3 INT, read and follow all warnings and instructions in this guide and documents at [enphase.com/support](https://enphase.com/support).

Safety warnings are listed on the back of this guide. These instructions are not meant to be a complete explanation of how to design and install an energy storage system. All installations must comply with national and local electrical codes and standards. Only Enphase certified electricians shall install, troubleshoot, or replace the IQ System Controller 3 INT.



## Section A

# Mounting an IQ System Controller 3 INT

## Tools/additional items required

S. NO	ITEM NAME	MINIMUM QUANTITY	SOURCE
1	Breakers of different ratings	4	Provided by installer
2	Conduits (with fittings and fitting tools) - IP55 and above (for non-rear entry systems)	As required	Provided by installer
3	IP55 conduit ground locknut (for non-rear entry systems)	1	Provided by installer
4	M6 pilot bit	1	Provided by installer
5	Screw driver	1	Provided by installer
6	Wrench	1	Provided by installer
7	Adjustable wrench	1	Provided by installer
8	Torque wrench up to 10 N m	1	Provided by installer
9	Level	1	Provided by installer
10	5/32" Allen key	2	Provided by installer
11	Conductor stripper	1	Provided by installer
12	Electrician's hole saw (2") or punch set	1 pair	Provided by installer
13	Stud finder	1	Provided by installer
14	Drill, drill bit extender	As required	Provided by installer
15	M6 lag bolts or screw 80 mm long (depending on attaching wall) for each wall-mount bracket	2	Provided by installer
16	Control wire	As required	Provided by installer*

\* Recommended Electra EAS7302PHV or the LAPP 1270802



**NOTE:**

The IQ System Controller 3 INT weighs 15.2 kg and will require two people to lift and align the unit.

## Section A - Mounting an IQ System Controller 3 INT

### Step 1: Plan a location for mounting the unit



- IQ System Controller 3 INT is IP55 rated and can be mounted both indoors and outdoors. Install the unit where it is not exposed to direct rainfall.
- Install this product where cables from PV, incoming mains, and batteries are easily accessible and can be terminated at the IQ System Controller 3 INT.

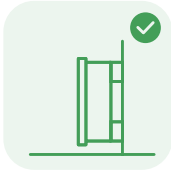

- This product is designed to be installed on the wall only. Do not install this product on the ground.
- The mounting surface must be able to support 15 kg.
- Follow all local standards and regulations while choosing a location for IQ System Controller 3 INT.

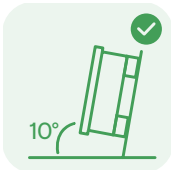

- Do not install the product on the ceiling. The unit must be accessible.
- Do not install the product on a wall with a slope of more than 10 degrees.
- Product should be installed upright. Do not install the product tilting forward.

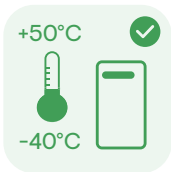

- The product operates within an ambient temperature range from -40°C to 50°C.
- Do not install this product in a place where it is directly exposed to sunlight.
- Do not install the product in a very dusty environment.



- This product must not be installed at altitudes above 2,000 m.



- In flood prone areas, ensure that the clearance from the ground is sufficient to avoid water ingress.

## Section A - Mounting an IQ System Controller 3 INT

### Step 2: Minimum clearance

This product must be installed with clearance at the left, right, top, bottom, and front of the product as shown in the figure.

Follow all local standards and regulations related to mounting of an IQ System Controller 3 INT.

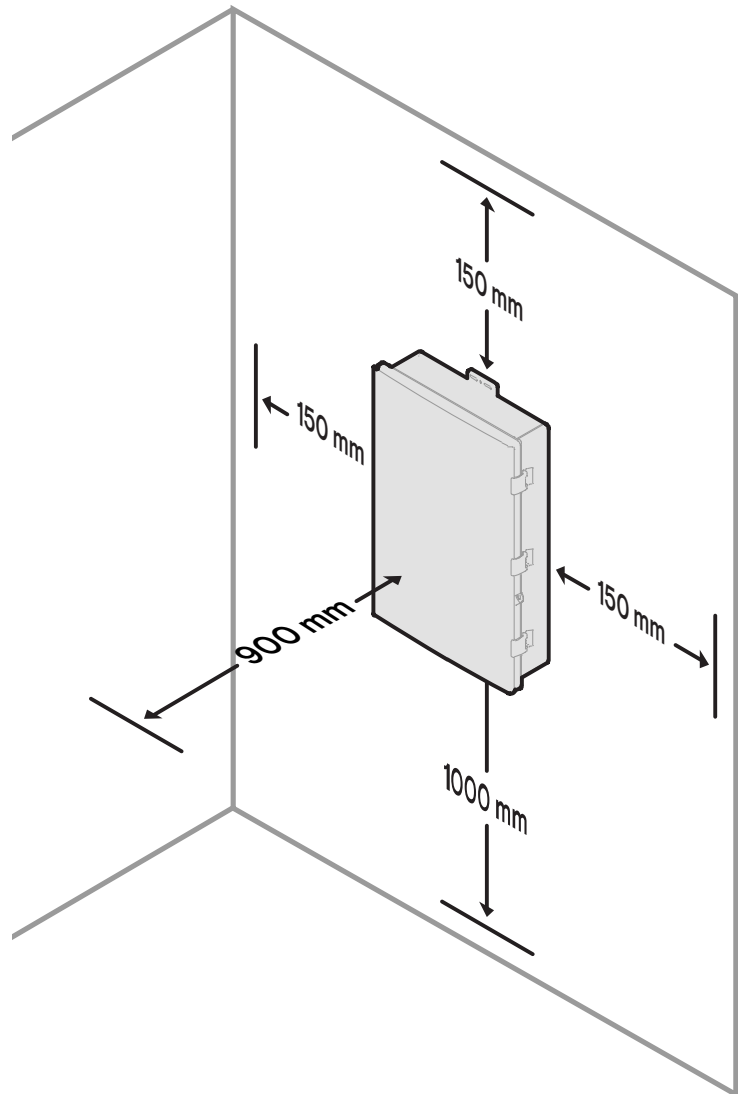
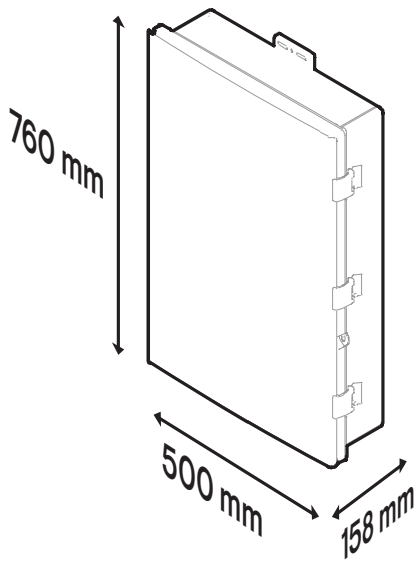

## Section A - Mounting an IQ System Controller 3 INT

### Step 3: Opening the door

Install the IQ System Controller 3 INT as per instructions below.  
Please note the following before installing:

- The IQ System Controller 3 INT weighs 15.2 kg and will require two people to lift and align the unit.
- Risk of injury and equipment damage. Avoid dropping the IQ System Controller 3 INT. Doing so may create a hazard, cause serious injury, and/or damage the equipment.
- Remove the door and keep it aside safely for ease of installation.

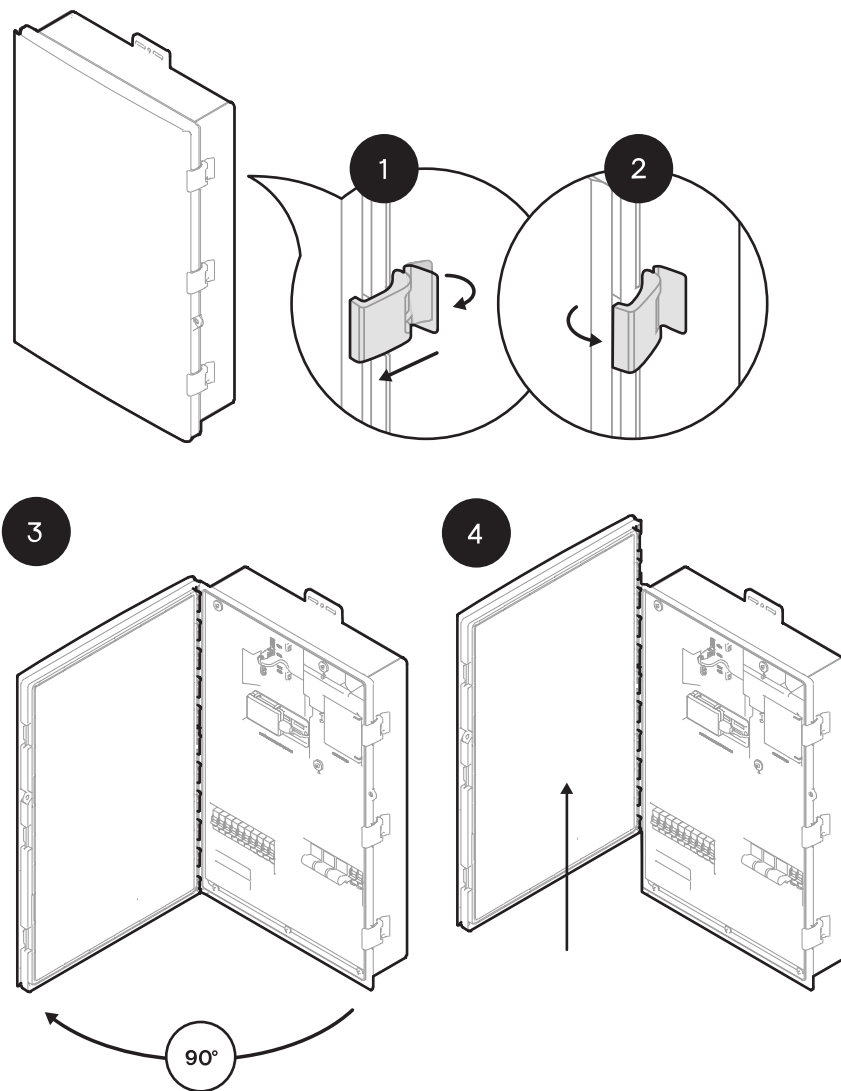

## Section A - Mounting an IQ System Controller 3 INT

### Step 4: Mounting the IQ System Controller 3 INT

Please note the following:

- Risk of electric shock. To maintain the warranty, do not modify the dead front other than to remove or replace filler plates, as needed.
- Place the IQ System Controller 3 INT on the wall so that the mounting holes at middle of the mounting tabs are aligned with the center of the stud. Mark the top center hole for predrilling and keep the unit aside safely.
- Adhere to local standards. Use washers between fastener heads and wall-mount bracket.

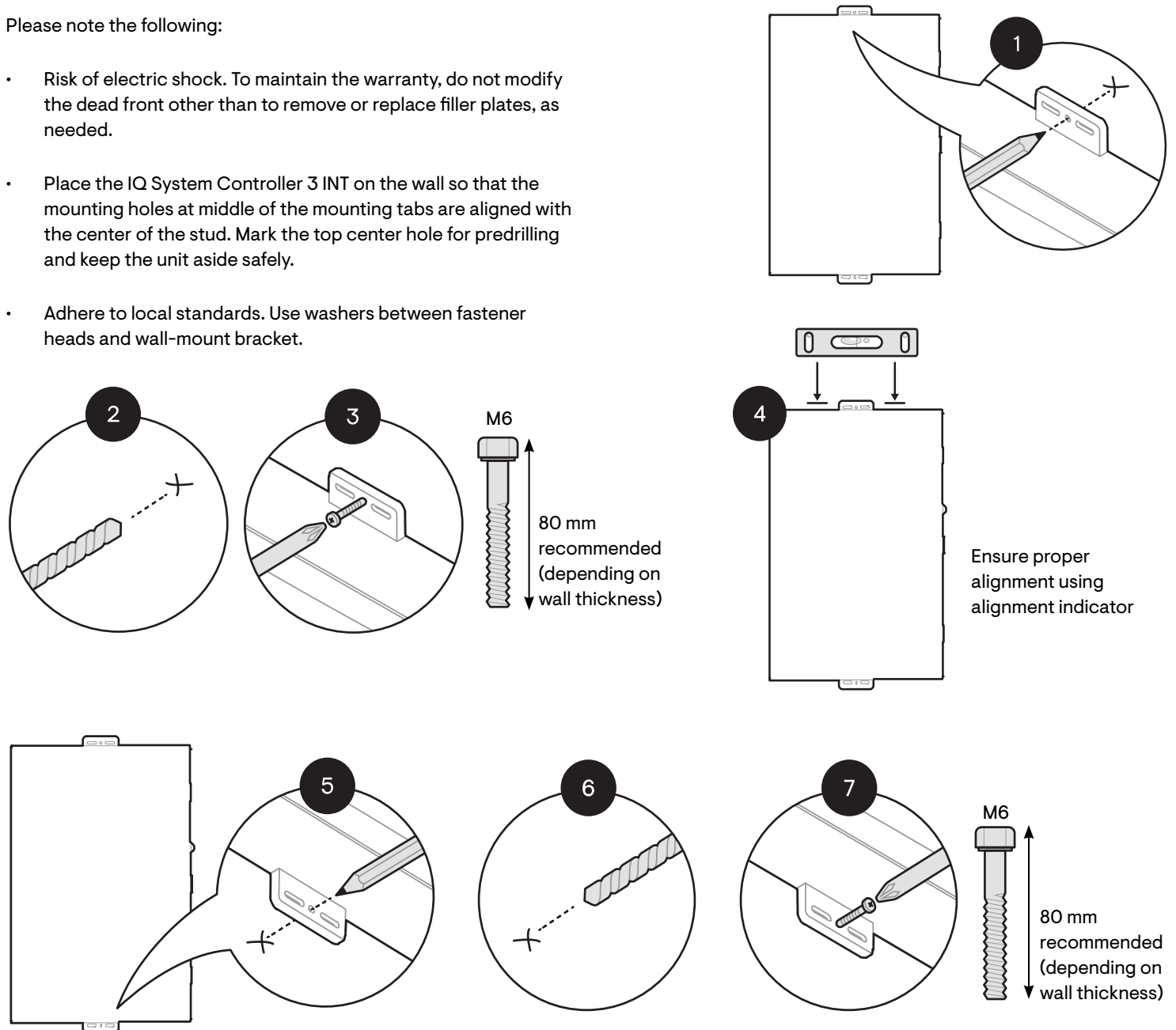

✓ **NOTE:** Use a drill bit extender for better access to mounting holes during installation.

⚠ **WARNING:** Do not drill the conduit holes on the wall when the unit is installed as it may lead to exposure of circuit boards to heavy dust. Conduit holes to be marked separately on the unit and wall for drilling.





## Section A - Mounting an IQ System Controller 3 INT

### Step 5: Opening the dead front

Before removing the dead front, ensure the IQ System Controller 3 INT is completely de-energized.

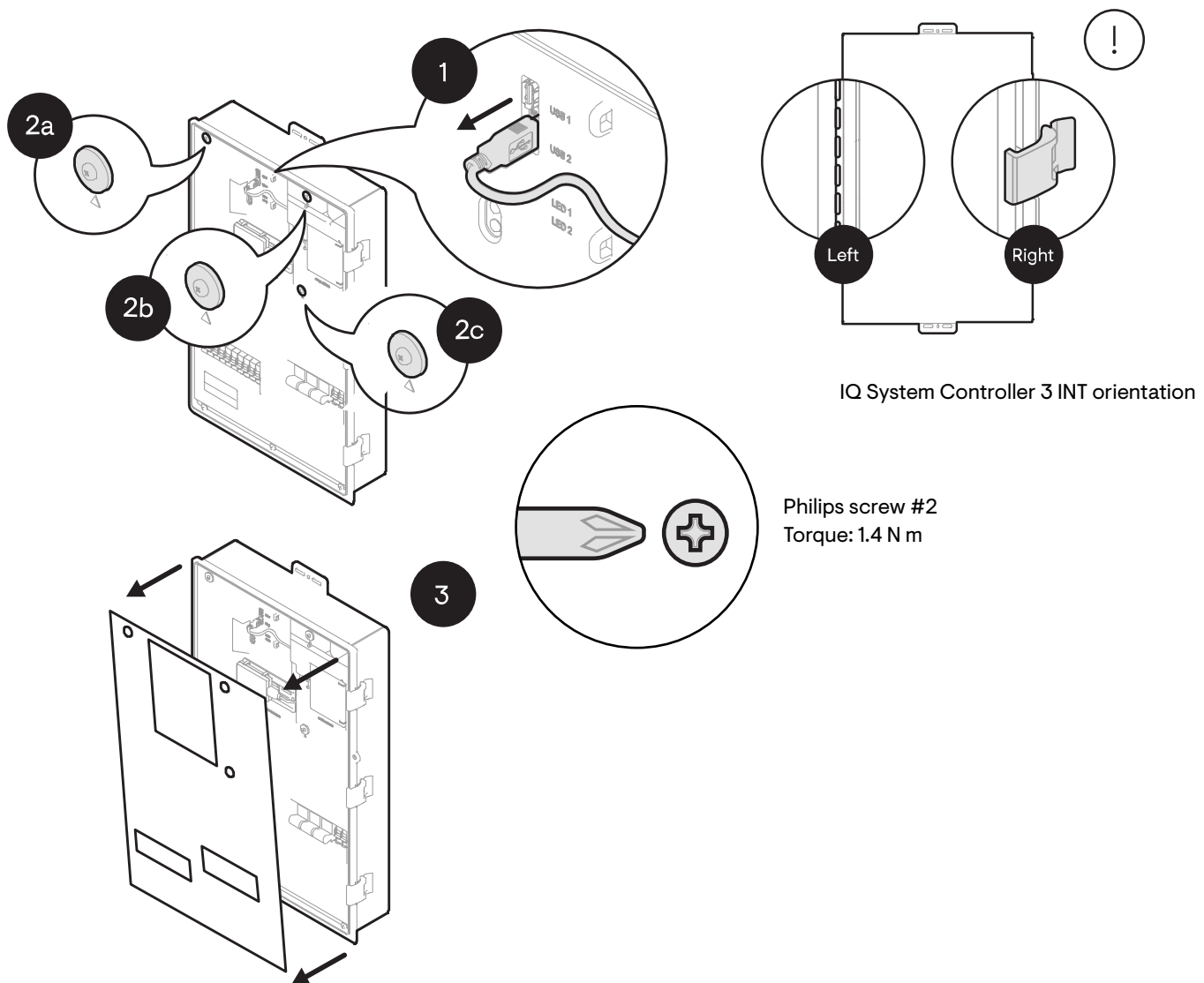
 Risk of equipment damage. Do not wire the IQ System Controller 3 INT when it is energized.



 **NOTE:**  
Step 1 shown above may not be required during initial installation as Cellular modem may not be connected.

## Section B - Wiring

# Internal view of IQ System Controller 3 INT

Once the dead front is removed the IQ System Controller 3 INT looks like the diagram below.

DIN rails are provided to install breakers. Use conductors (line, neutral, and ground) and breakers of proper ampacity and protection requirements according to local codes.

Before connecting the wires, refer to the wiring table, torque recommendations, and local codes for any specific local requirements.



IQ Gateway USB connection

 Connect at the time of installation

Look at label on door of unit to understand LED and Button functions.

Ethernet port

Manual override

PV lugs

IQ Battery lugs

DER breakers

System shutdown terminal

Ground terminals

Backup load lugs

Non-backup load lugs

Mains lugs

DIN rails

IQ Gateway breaker (pre-installed and pre-wired)

Non-backup loads breaker

Backup loads breaker

Neutral terminals

Mains breaker



### NOTE:

Breakers for IQ Battery, mains, and non-backup/backup loads are not supplied with IQ System Controller 3 INT and must be purchased separately.

In Australia and New Zealand, the neutral will not be switched.



Ensure to connect the USB cable from controller PCBA to IQ Gateway before closing the dead front.



Ensure that wires are not pinched while re-attaching the dead front.

## Section B - Wiring

### Power terminals

Connect DER, mains, and load wires as mentioned below:

- Backup loads: backup load lug (1), neutral bar (10)
- Mains: mains lugs (2), neutral bar (10), earth bar (9)
- Non-backup loads: non-backup load lugs (3), neutral bar (10), earth bar (9)
- PV: PV L1, L2, L3 (4), neutral lugs (6) through PV breaker (B1)
- IQ Battery: IQ Battery L1, L2, L3 (5), neutral bar (10)

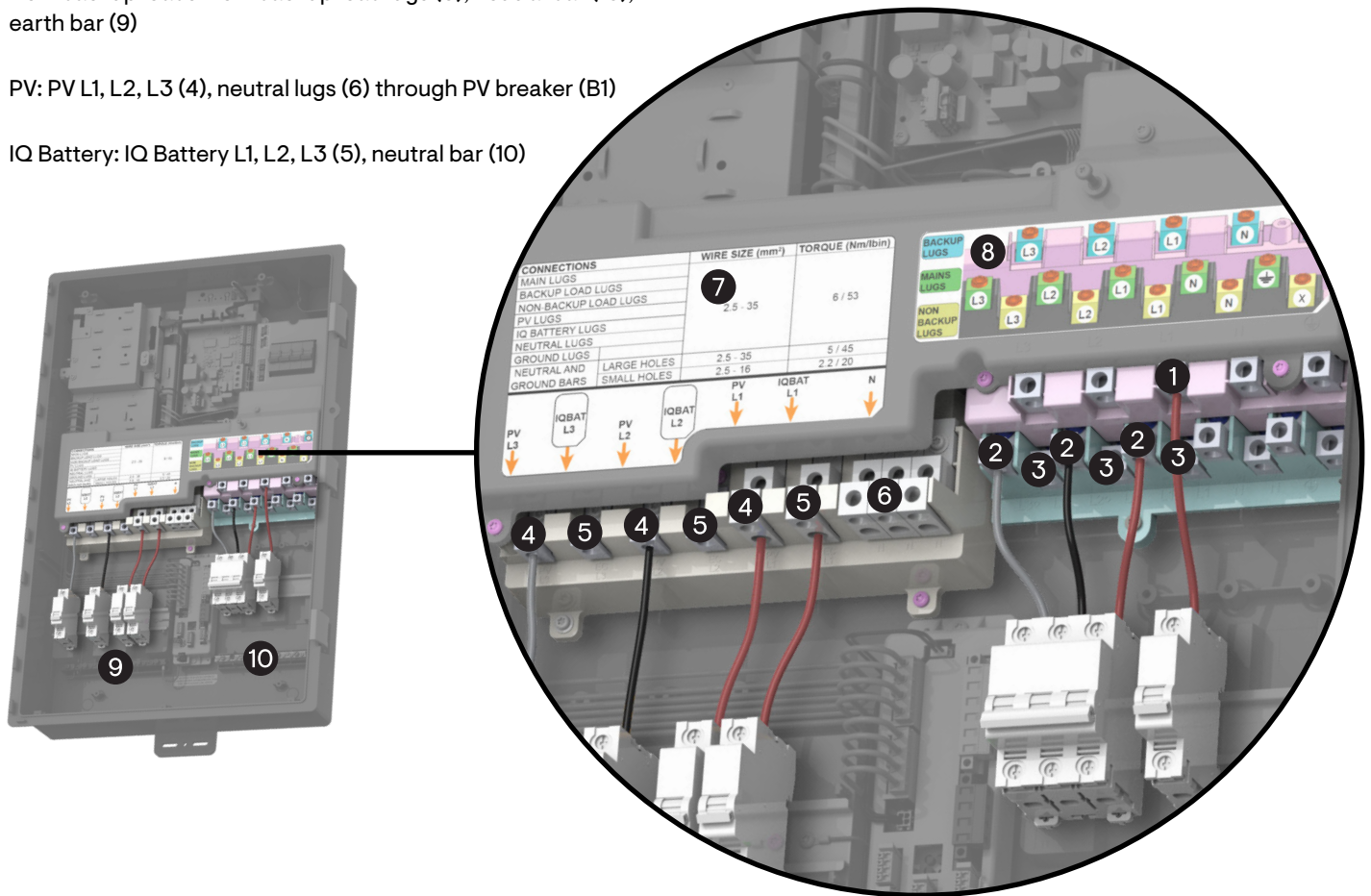

CONNECTIONS	WIRE SIZES (Sq. mm)	TORQUE (N m)	STRIP LENGTH (mm)
IQ System Controller 3 INT lugs	2.5 - 35	6	12
Neutral and ground bar large holes	2.5 - 35	5	10
Neutral and ground bar small holes	2.5 - 16	2.2	10

#### NOTE:

Connect L1, L2, and L3 mains, loads, and PV as indicated on equipment labels (12, 13). Maintaining correct phase continuity is necessary for proper operation.

- |                         |                    |
|-------------------------|--------------------|
| 1 Backup load lug       | 8 Main relay label |
| 2 Mains lugs            | 9 Earth bar        |
| 3 Non-backup load lugs  | 10 Neutral bar     |
| 4 PV lugs               |                    |
| 5 IQ Battery lugs       |                    |
| 6 PV neutral lugs       |                    |
| 7 DER termination label |                    |







## Section B - Wiring

### Recommended breaker selection

POSITION	# PHASES	CONFIGURATION [PER CIRCUIT BRANCH]
PV	PV on three-phase	4-pole PV MCB pre-installed in the unit Must use additional 4-pole Miniature Circuit Breaker (MCB) for any additional three-phase PV branch circuit
	PV on single-phase	4-pole PV MCB pre-installed in the unit, use for up to 2 single-phase 25 A PV branch circuits 1 x 2-pole MCB (Max 25 A) for additional single-phase PV branch circuit
IQ Battery	Single-phase	1 x 1-pole MCB (20 A for 1 x IQ Battery 5 - Max 80 A for 4 x daisy-chained batteries)
	Three-phase	3 x 1-pole MCB (20 A for 1 x IQ Battery 5 - Max 80 A for 4 x daisy-chained batteries)
Mains	Three-phase	1 x 3-pole MCB (Max 63 A)
	Single-phase	1-pole MCB (Max 63 A)
Backup	Single-phase	1-pole MCB (Max 63 A)

		SCHNEIDER/CLIPSAL	HAGER	LEGRAND
For mains breaker	1-pole	MX9MC1XXR	MSN1XXR	4 034 XX
	3-pole	MX9MC3XXR	MSN3XXR	4 035 XX
For other positions	1-pole	M9MC1XX/4CB1XX-6	MSN1XX	4 034 XX
	2-pole	M9MC2XX/4CB2XX-6	MSN2XX	4 035 XX
	3-pole	M9MC3XX/4CB3XX-6	MSN3XX	4 035 XX
	4-pole	M9MC4XX/4CB4XX-6	MSN4XX	4 035 XX
		XX is current rating		XX - Current code to be identified from breaker product manual

#### IEC AC power circuit wiring colour codes

Wire type	Colour code (IEC)
AC three-phase (L1)	
AC three-phase (L2)	
AC three-phase (L3)	
Neutral (N)	
Protective earth (PE) ground (GND)	
Single-phase (L) (1-wire line)	

 **NOTE:** IQ Gateway breaker is pre-installed and pre-wired along with IQ System Controller 3 INT. Use this breaker to power cycle the IQ Gateway only if required for troubleshooting. Do not change the breaker position from slot number 19 (indicated in dead front).

#### Legends indicating breakers in scenario pages

-  B1 PV breaker
-  B2 IQ Battery breaker
-  B3 Mains breaker
-  B4 Backup breaker
-  B5 Non-backup breaker
-  B6 IQ Gateway breaker

 **NOTE:** Breakers for IQ Battery, mains, and non-backup/backup loads are not supplied with IQ System Controller 3 INT and must be purchased separately.

Size the conductors and breakers according to local electrical codes. All final sub-circuits to follow IEC and AS/NZS colour code indicated in this page.

Ensure that the wires connected to the breakers are tightened with torque as recommended by the breaker manufacturer.

## Section B - Wiring

### Drill conduits

Drill conduit entry holes as needed, and install conduit grounding lugs for each opening. Be sure to reseal unused conduit entry holes with sealing plugs.

There are options for conduit entry from bottom, the two sides, and rear. Maximum sizes for bottom and rear conduit are also shown below.



**WARNING:** Do not drill the conduit holes on the wall when the unit is installed as it may lead to exposure of circuit boards to heavy dust. Conduit holes to be marked separately on the unit and wall for drilling.

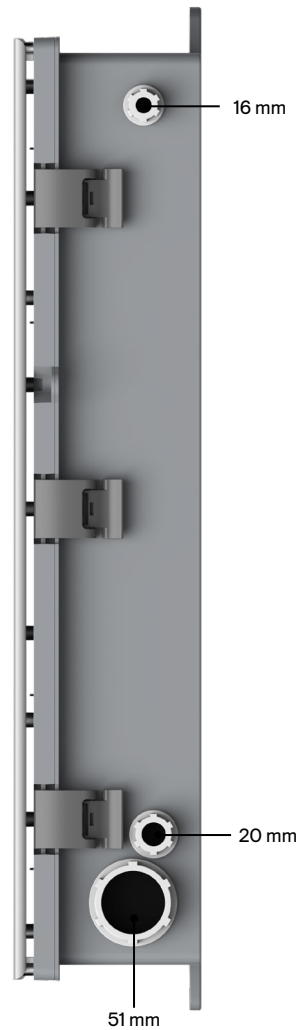

Right side view

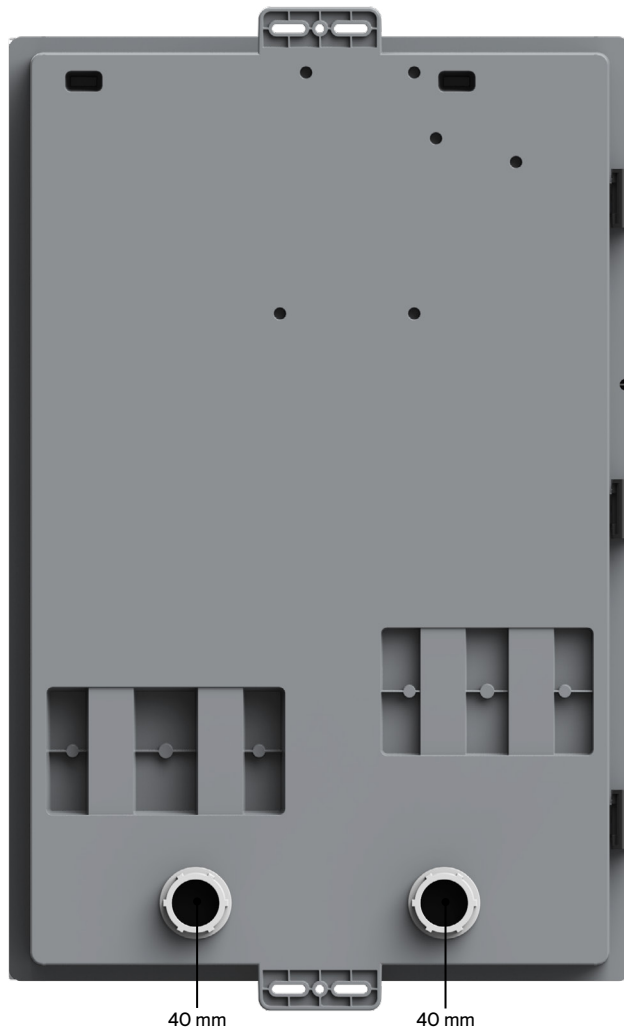

Back view



Left side view

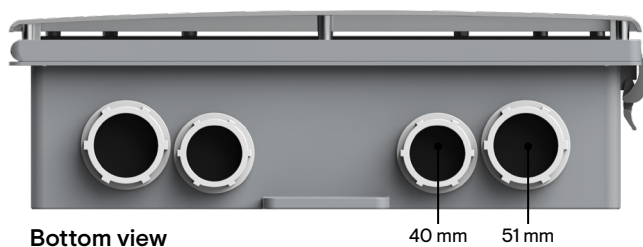

Bottom view



**NOTE:** Dimensions in the images indicate the diameter of conduit drill holes.

10 mm thickness to be considered for conduit thickness.

## Section B - Wiring

# Single-phase home

## Field wiring of mains

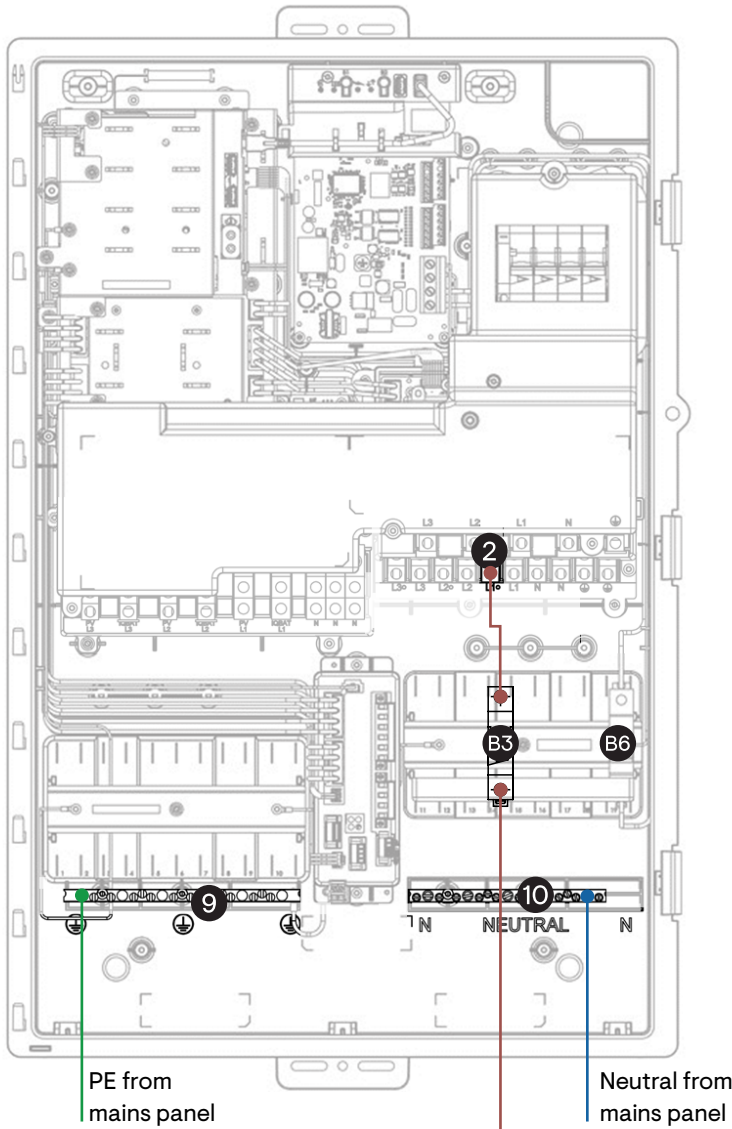

CONNECTIONS	WIRE SIZES (Sq.mm)	TORQUE (N m)	STRIP LENGTH (mm)
IQ System Controller 3 INT lugs	2.5 - 35	6	12
Neutral and ground bar large holes	2.5 - 35	5	10
Neutral and ground bar small holes	2.5 - 16	2.2	10

- 2 Mains L1
- 9 Earth bar
- 10 Neutral bar
- B3 Mains breaker^
- B6 IQ Gateway breaker (pre-installed and pre-wired)

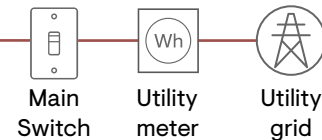

**NOTE:** Do not change the IQ Gateway breaker position from slot number 19 (indicated in dead front).

^ Breakers should be sized as per local requirements and procured separately. They are not supplied with the IQ System Controller 3 INT.

PE - Protective earth

## Section B - Wiring

# Single-phase home

## Field wiring of loads

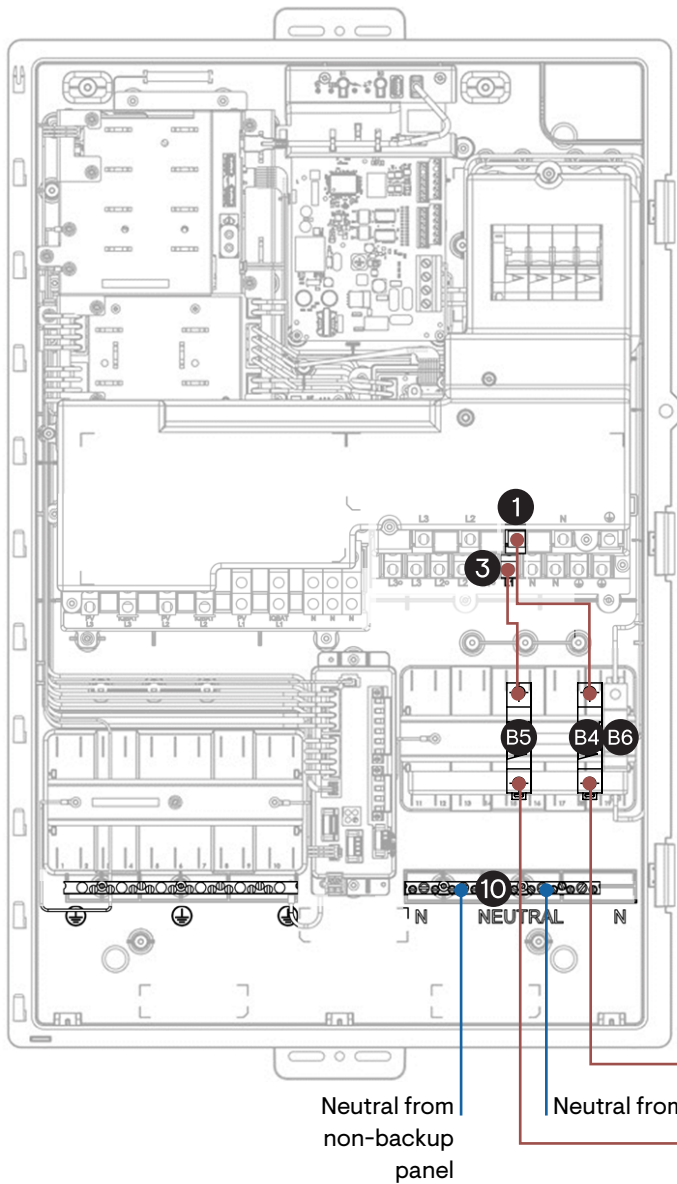

CONNECTIONS	WIRE SIZES (Sq. mm)	TORQUE (N m)	STRIP LENGTH (mm)
IQ System Controller 3 INT lugs	2.5 - 35	6	12
Neutral and ground bar large holes	2.5 - 35	5	10
Neutral and ground bar small holes	2.5 - 16	2.2	10

- 1 Backup L1
- 3 Non-backup L1
- 10 Neutral bar
- B4 Backup breaker<sup>^</sup>
- B5 Non-backup breaker<sup>^</sup>
- B6 IQ Gateway breaker (pre-installed and pre-wired)

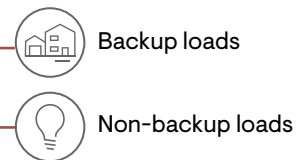

**NOTE:** Do not change the IQ Gateway breaker position from slot number 19 (indicated in dead front).

<sup>^</sup> Breakers should be sized as per local requirements and procured separately. They are not supplied with the IQ System Controller 3 INT.

## Section B - Wiring

# Single-phase home

## Field wiring one branch of single-phase PV

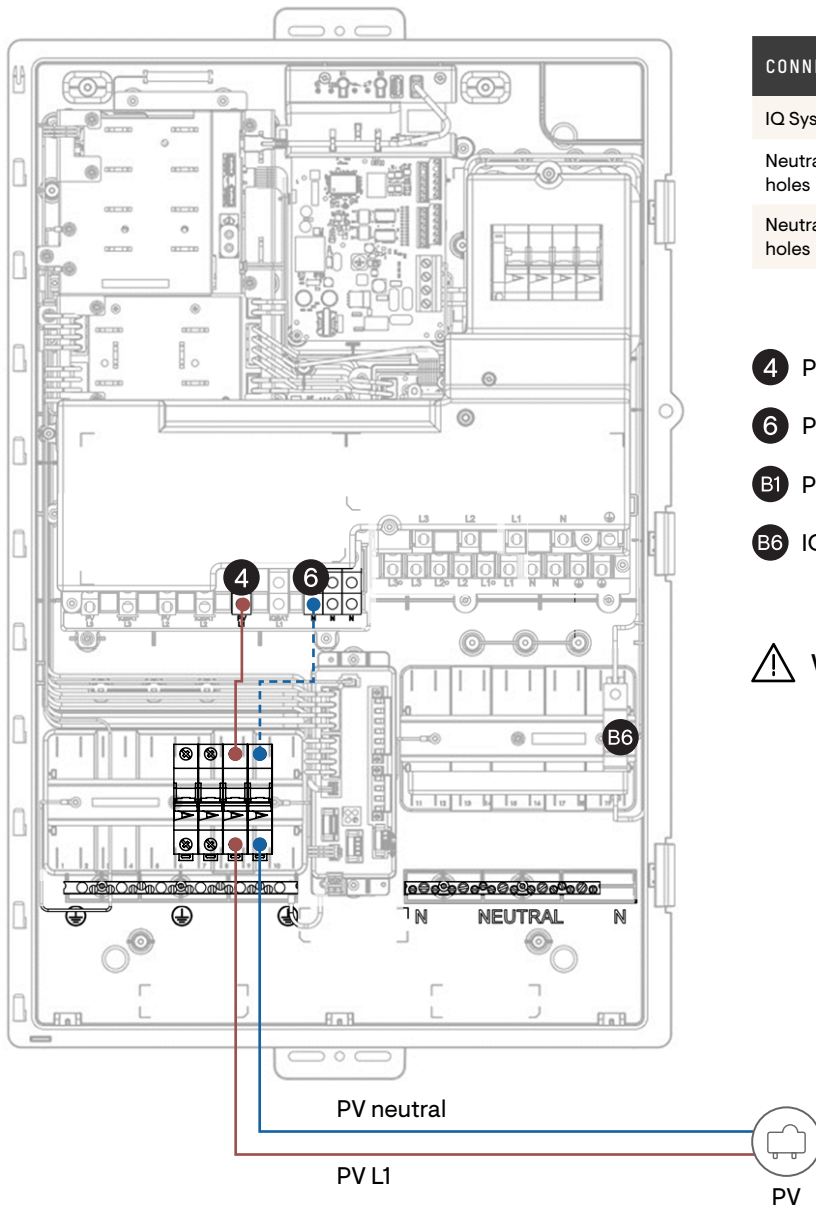

CONNECTIONS	WIRE SIZES (Sq. mm)	TORQUE (N m)	STRIP LENGTH (mm)
IQ System Controller 3 INT lugs	2.5 - 35	6	12
Neutral and ground bar large holes	2.5 - 35	5	10
Neutral and ground bar small holes	2.5 - 16	2.2	10

- 4 PV L1
- 6 PV neutral lug (pre-wired to neutral pole on 4-pole breaker)
- B1 PV breaker\*
- B6 IQ Gateway breaker (pre-installed and pre-wired)

**WARNING!** PV neutral must be connected to breaker.

**NOTE:** Do not change the IQ Gateway breaker position from slot number 19 (indicated in dead front).

\* Pre-installed four-pole breaker to be used for PV wiring.



## Section B - Wiring

### Single-phase home

Field wiring single-phase battery and one branch of single-phase PV

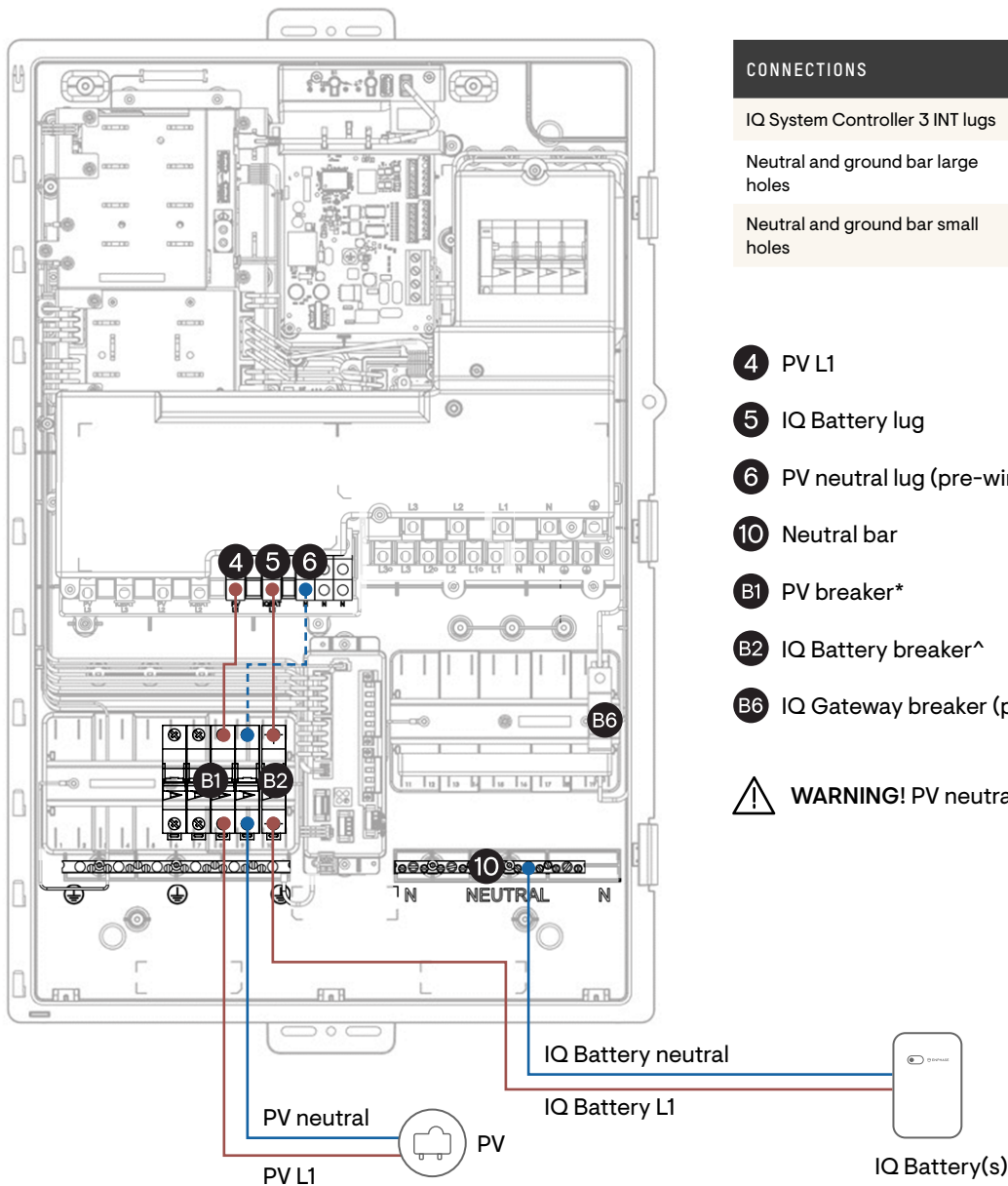

CONNECTIONS	WIRE SIZES (Sq.mm)	TORQUE (N m)	STRIP LENGTH (mm)
IQ System Controller 3 INT lugs	2.5 - 35	6	12
Neutral and ground bar large holes	2.5 - 35	5	10
Neutral and ground bar small holes	2.5 - 16	2.2	10

- ④ PV L1
- ⑤ IQ Battery lug
- ⑥ PV neutral lug (pre-wired to neutral pole on 4-pole breaker)
- ⑩ Neutral bar
- ⓑ1 PV breaker\*
- ⓑ2 IQ Battery breaker^
- ⓑ6 IQ Gateway breaker (pre-installed and pre-wired)

⚠ **WARNING!** PV neutral must be connected to breaker.

✔ **NOTE:** Do not change the IQ Gateway breaker position from slot number 19 (indicated in dead front).

\* Pre-installed four-pole breaker to be used for PV wiring.

^ Breakers should be sized as per local requirements and procured separately. They are not supplied with the IQ System Controller 3 INT.

## Section B - Wiring

# Single-phase home

## Field wiring two branches of single-phase PV

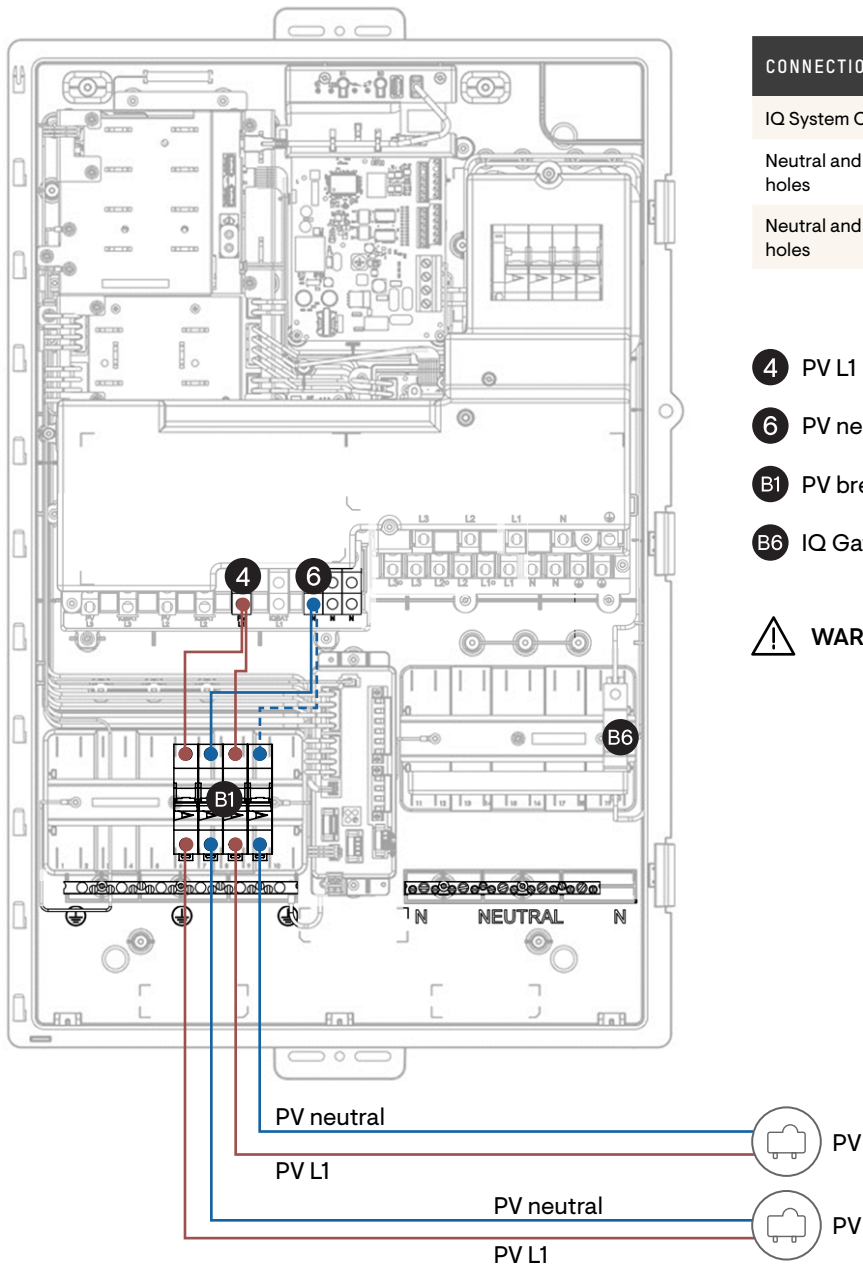

CONNECTIONS	WIRE SIZES (Sq. mm)	TORQUE (N m)	STRIP LENGTH (mm)
IQ System Controller 3 INT lugs	2.5 - 35	6	12
Neutral and ground bar large holes	2.5 - 35	5	10
Neutral and ground bar small holes	2.5 - 16	2.2	10

- 4 PV L1
- 6 PV neutral lug (pre-wired to neutral pole on 4-pole breaker)
- B1 PV breaker\*
- B6 IQ Gateway breaker (pre-installed and pre-wired)

**WARNING!** PV neutral must be connected to breaker.

**NOTE:** Do not change the IQ Gateway breaker position from slot number 19 (indicated in dead front).

\* Pre-installed four-pole breaker to be used for PV wiring.

## Section B - Wiring

### Single-phase home

Field wiring two branches of single-phase PV and single-phase IQ Battery

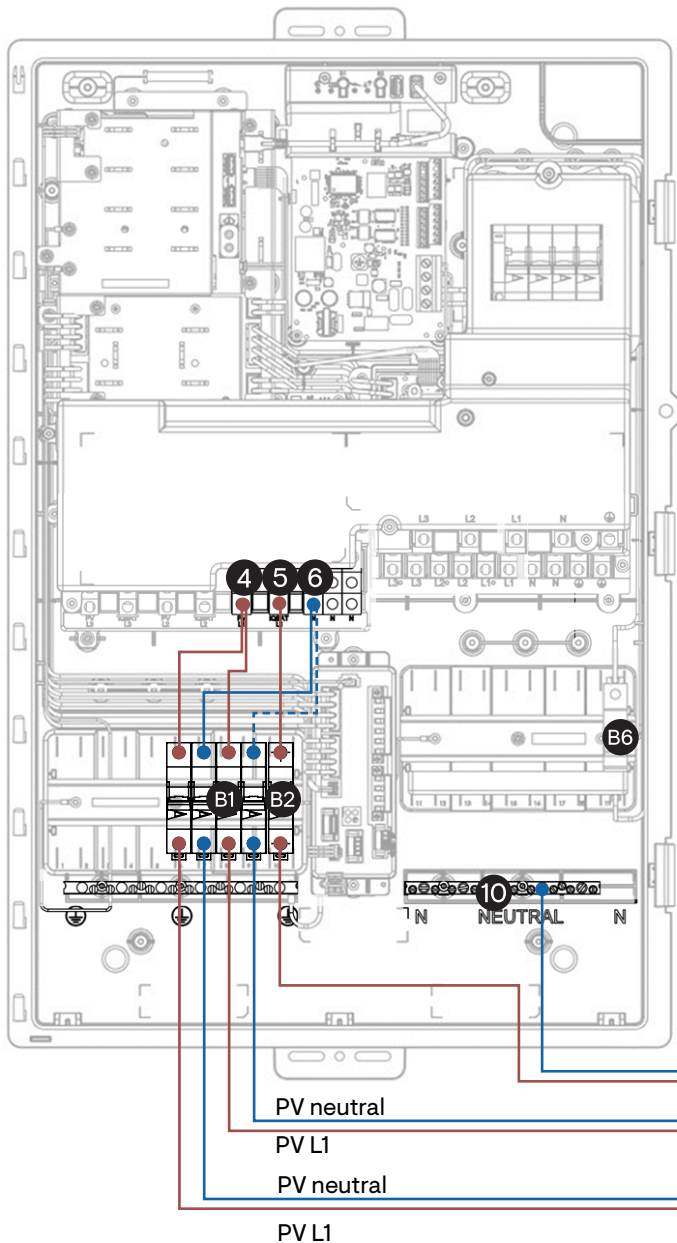

CONNECTIONS	WIRE SIZES (Sq. mm)	TORQUE (N m)	STRIP LENGTH (mm)
IQ System Controller 3 INT lugs	2.5 - 35	6	12
Neutral and ground bar large holes	2.5 - 35	5	10
Neutral and ground bar small holes	2.5 - 16	2.2	10

- ④ PV L1
- ⑤ IQ Battery lug
- ⑥ PV neutral lug (pre-wired to neutral pole on 4-pole breaker)
- ⑩ Neutral bar
- ⓑ1 PV breaker\*
- ⓑ2 IQ Battery breaker^
- ⓑ6 IQ Gateway breaker (pre-installed and pre-wired)

⚠ **WARNING!** PV neutral must be connected to breaker.

✓ **NOTE:** The neutral from the 2nd single-phase PV branch is landed on the pre-installed 4-pole breaker and then terminated at PV neutral lug (6).

✓ **NOTE:** Do not change the IQ Gateway breaker position from slot number 19 (indicated in dead front).

\* Pre-installed four-pole breaker to be used for PV wiring.

^ Breakers should be sized as per local requirements and procured separately. They are not supplied with the IQ System Controller 3 INT.

## Section B - Wiring

### Single-phase home

System field wiring single-phase battery and one branch of single-phase PV

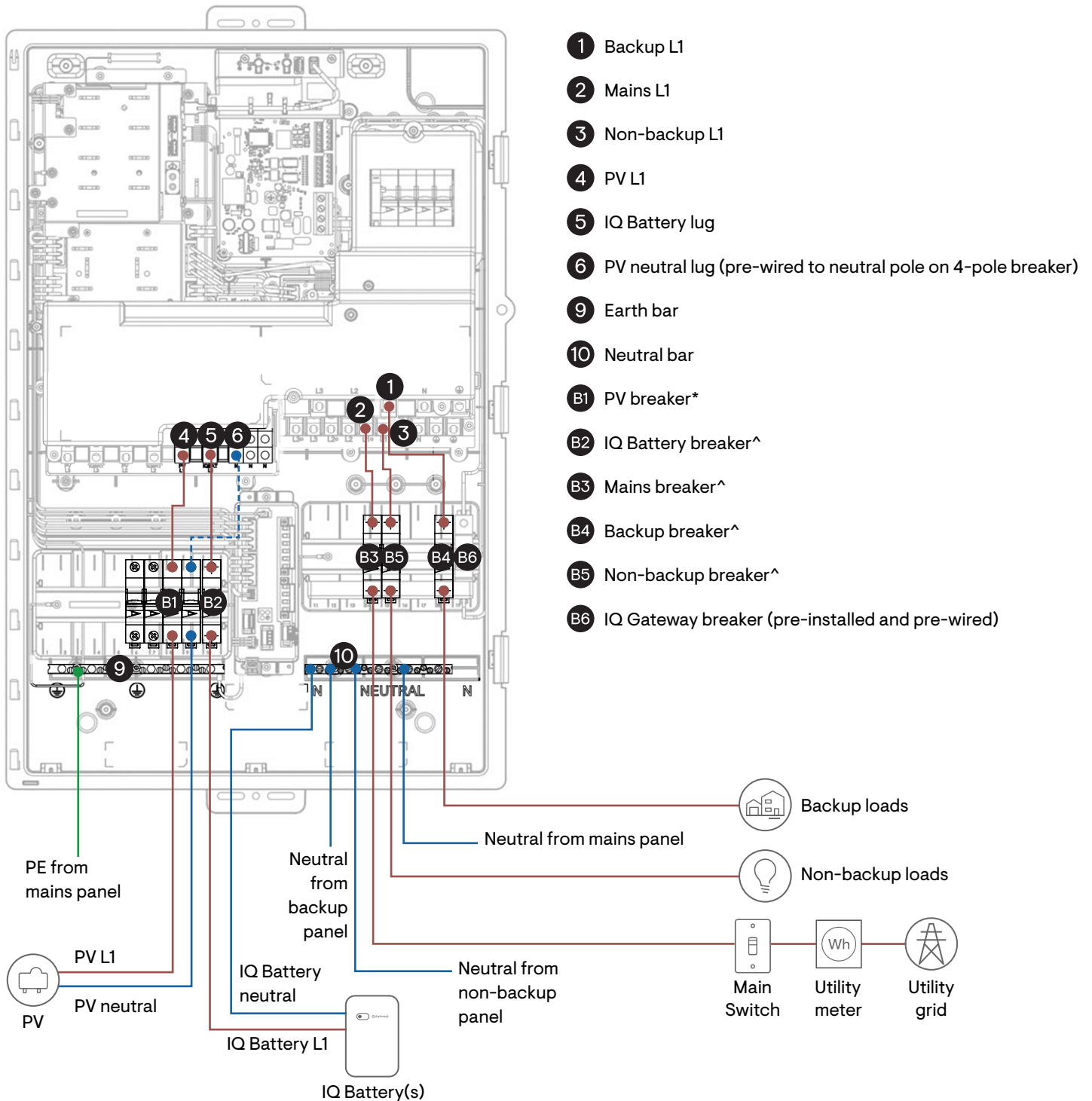

## Section B - Wiring

# Three-phase home

## Field wiring of mains

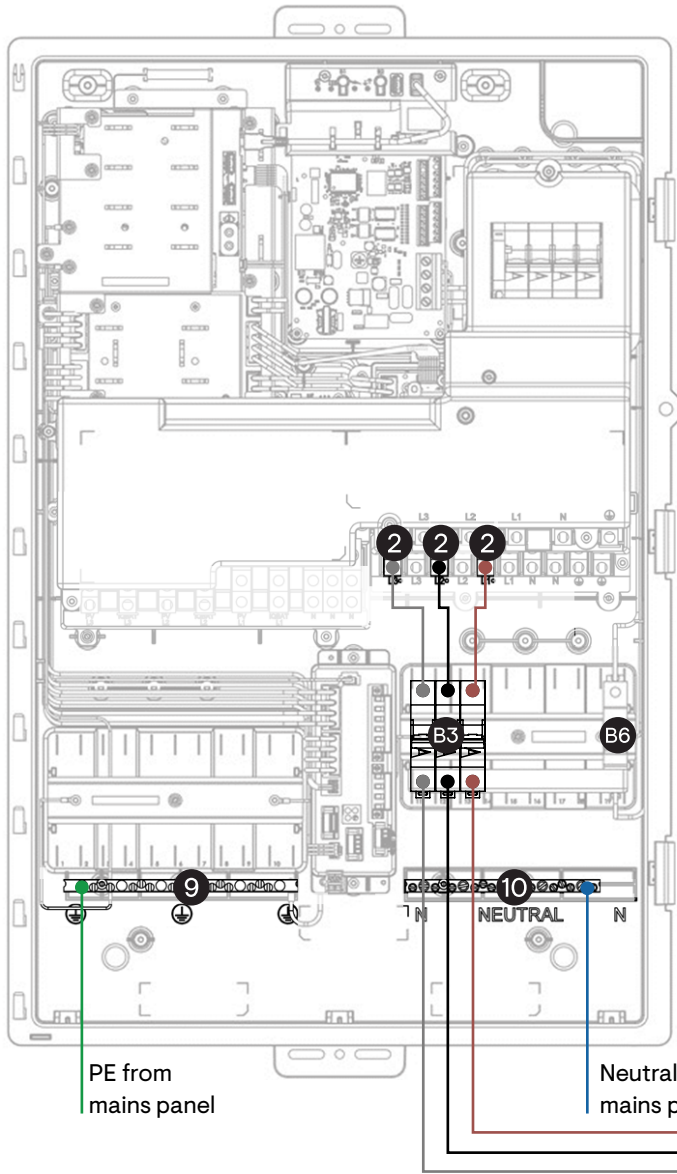

CONNECTIONS	WIRE SIZES (Sq. mm)	TORQUE (N m)	STRIP LENGTH (mm)
IQ System Controller 3 INT lugs	2.5 - 35	6	12
Neutral and ground bar large holes	2.5 - 35	5	10
Neutral and ground bar small holes	2.5 - 16	2.2	10

- 2 Mains L1
- 9 Earth bar
- 10 Neutral bar
- B3 Mains breaker^
- B6 IQ Gateway breaker (pre-installed and pre-wired)

PE from mains panel

Neutral from mains panel

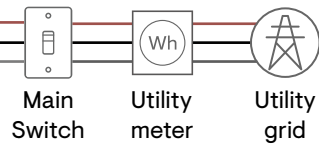

NOTE: Do not change the IQ Gateway breaker position from slot number 19 (indicated in dead front).

^ Breakers should be sized as per local requirements and procured separately. They are not supplied with the IQ System Controller 3 INT.

## Section B - Wiring

# Three-phase home

## Field wiring of loads

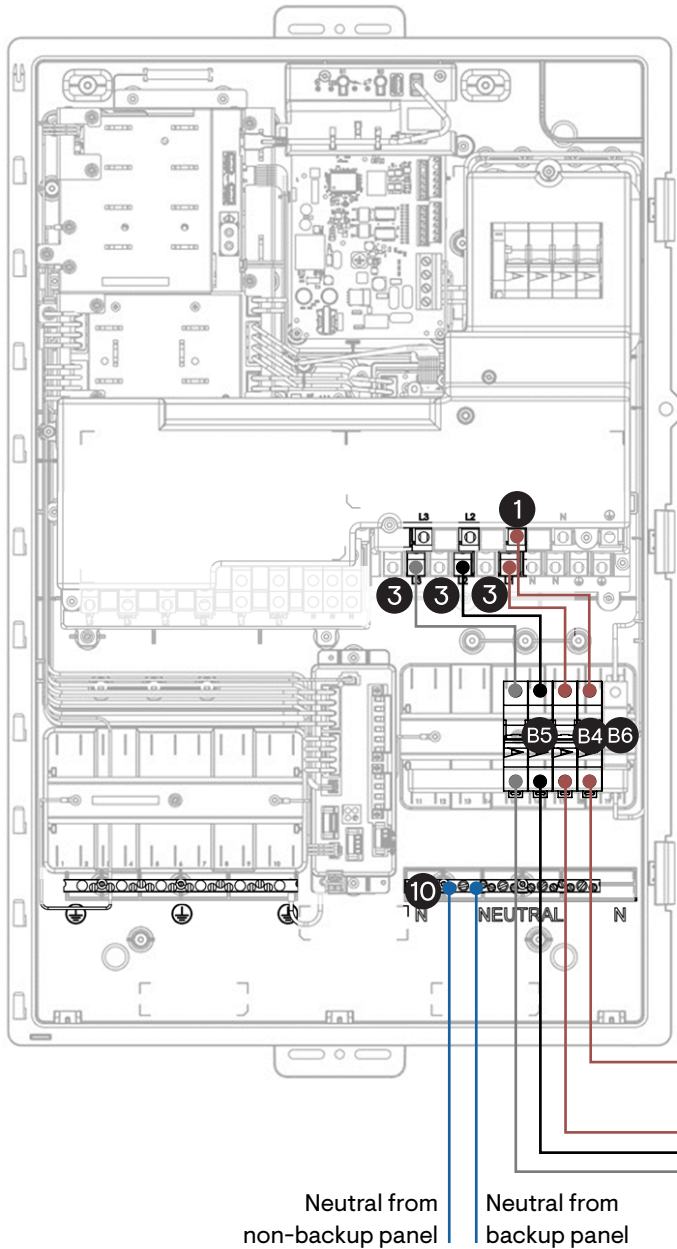

CONNECTIONS	WIRE SIZES (Sq. mm)	TORQUE (N m)	STRIP LENGTH (mm)
IQ System Controller 3 INT lugs	2.5 - 35	6	12
Neutral and ground bar large holes	2.5 - 35	5	10
Neutral and ground bar small holes	2.5 - 16	2.2	10

- 1 Backup L1
- 3 Non-backup lugs
- 10 Neutral bar
- B4 Backup breaker^
- B5 Non-backup breaker^
- B6 IQ Gateway breaker (pre-installed and pre-wired)

 Backup loads

 Non-backup loads

 **NOTE:** Do not change the IQ Gateway breaker position from slot number 19 (indicated in dead front).

^ Breakers should be sized as per local requirements and procured separately. They are not supplied with the IQ System Controller 3 INT.

## Section B - Wiring

# Three-phase home

## Field wiring three-phase PV

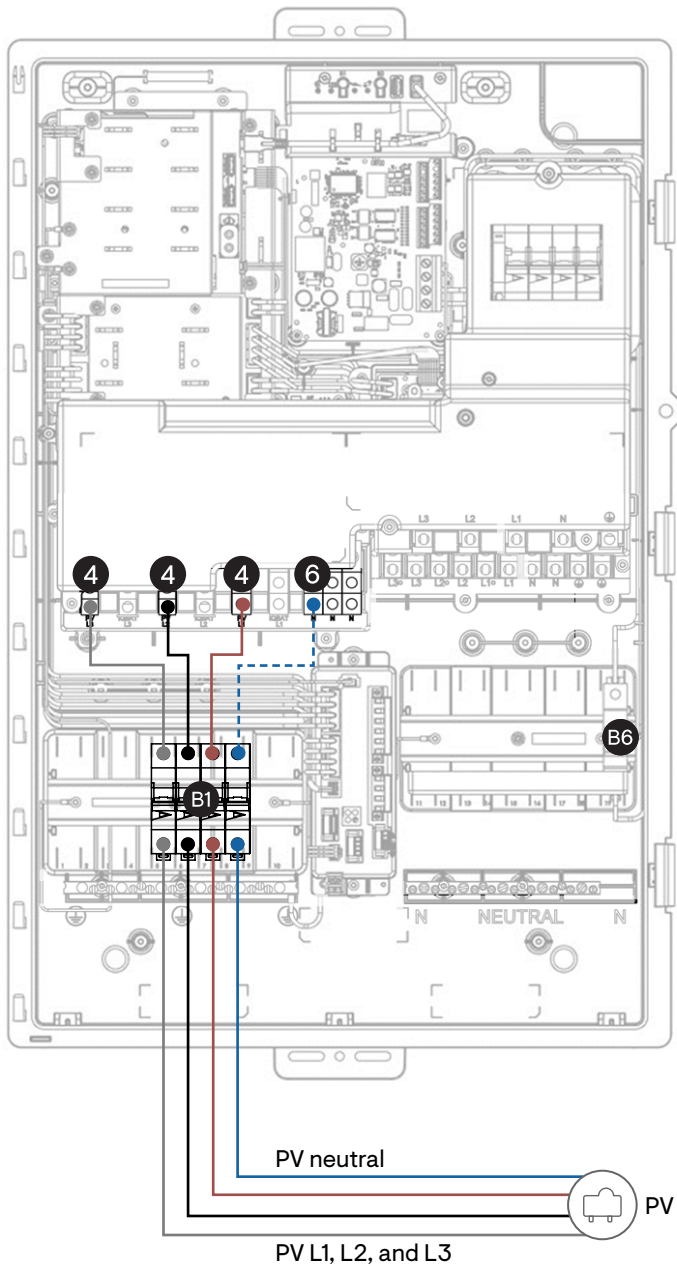

CONNECTIONS	WIRE SIZES (Sq. mm)	TORQUE (N m)	STRIP LENGTH (mm)
IQ System Controller 3 INT lugs	2.5 - 35	6	12
Neutral and ground bar large holes	2.5 - 35	5	10
Neutral and ground bar small holes	2.5 - 16	2.2	10

- ④ PV lugs
- ⑥ PV neutral lug (pre-wired to neutral pole on 4-pole breaker)
- ⓑ1 PV breaker\*
- ⓑ6 IQ Gateway breaker (pre-installed and pre-wired)

⚠ **WARNING!** PV neutral must be connected to breaker.

✔ **NOTE:** Do not change the IQ Gateway breaker position from slot number 19 (indicated in dead front).

\* Pre-installed four-pole breaker to be used for PV wiring.

## Section B - Wiring

# Three-phase home

## Field wiring three-phase PV and three-phase IQ Battery

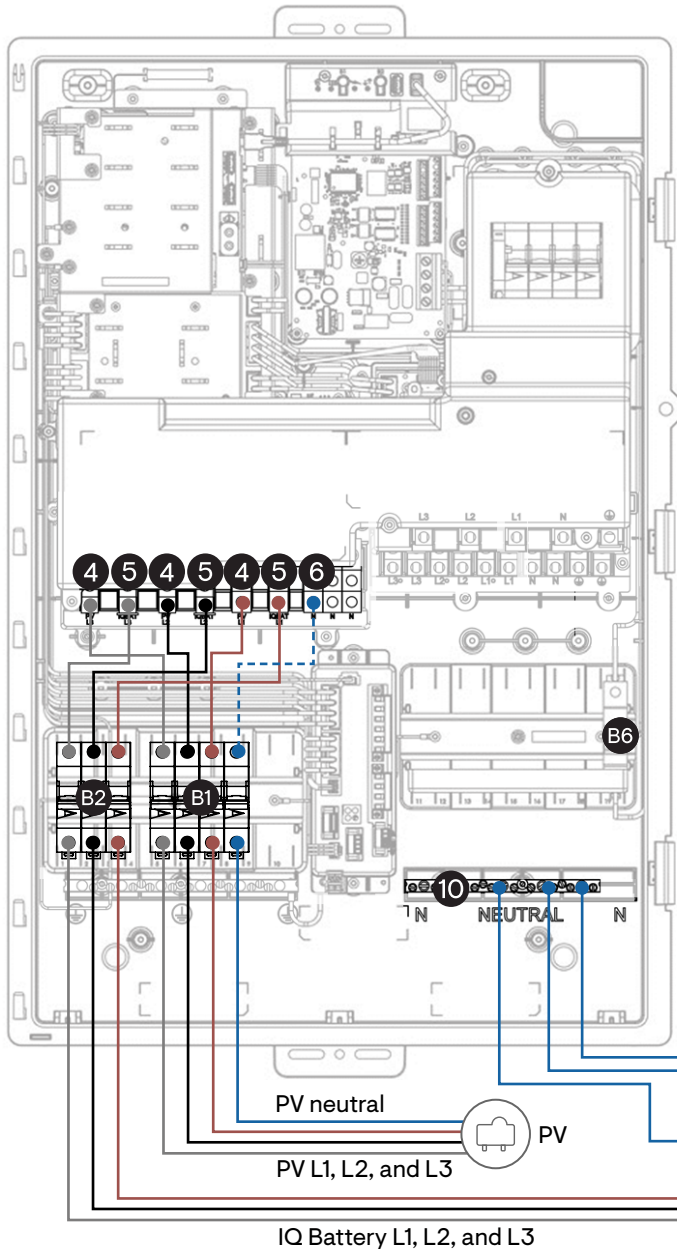

CONNECTIONS	WIRE SIZES [Sq.mm]	TORQUE [N m]	STRIP LENGTH [mm]
IQ System Controller 3 INT lugs	2.5 - 35	6	12
Neutral and ground bar large holes	2.5 - 35	5	10
Neutral and ground bar small holes	2.5 - 16	2.2	10

- 4 PV lugs
- 5 IQ Battery lugs
- 6 PV neutral lug (pre-wired to neutral pole on 4-pole breaker)
- 10 Neutral bar
- B1 PV breaker\*
- B2 IQ Battery breaker^
- B6 IQ Gateway breaker (pre-installed and pre-wired)

**WARNING!** PV neutral must be connected to breaker.

**NOTE:** Do not change the IQ Gateway breaker position from slot number 19 (indicated in dead front).

**WARNING!** Do not daisy chain neutral wire across batteries on different phases. Each phase of batteries must have a separate neutral wire that is terminated on the neutral bar in the IQ System Controller 3 INT.

\* Pre-installed four-pole breaker to be used for PV wiring.

^ Breakers should be sized as per local requirements and procured separately. They are not supplied with the IQ System Controller 3 INT.



## Section B - Wiring

# Wiring control (CTRL) cable to headers

IQ System Controller 3 INT supports wired control connections.

✔ **NOTE:** Use Enphase recommended cables, headers and also refer to local codes for any specific local requirements.

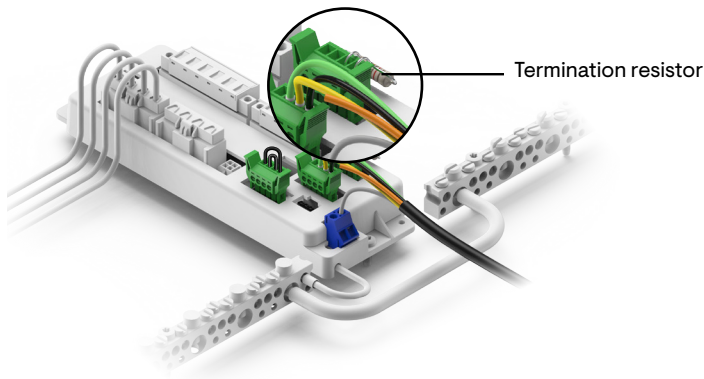

**Scenario 1:** When IQ System Controller 3 INT is a terminal node for the control network (at the end of the control cable loop), use a connector with a termination resistor in the terminal port.

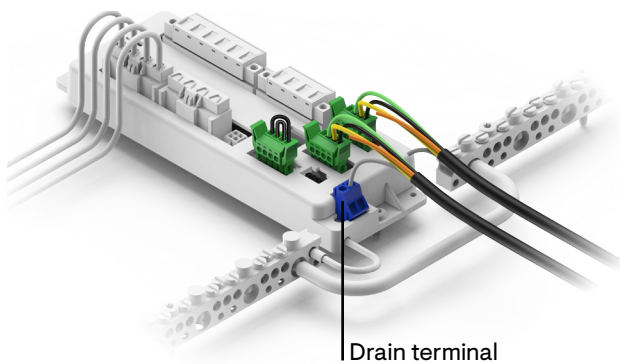

**Scenario 2:** When IQ System Controller 3 INT is not a terminal node for the control network (in the middle of the control cable loop), terminate the control wires on both the connectors.

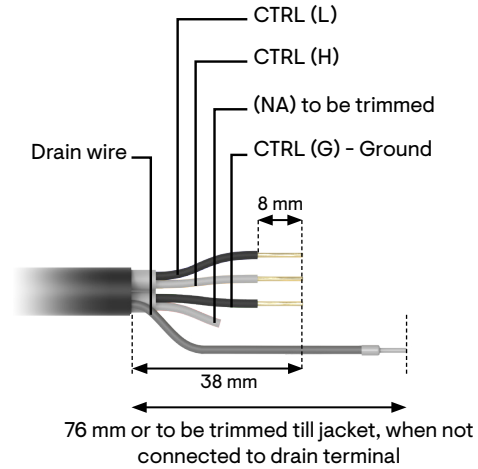

- Control wiring colours are indicative and might differ for different manufacturers
- The control cable must be stripped to the recommended dimensions as indicated above, and then connected to the header

The tested and supported control cable make and models are: Electra EAS7302PHV/EAS7502PHV or the LAPP 1270802.

## Section B - Wiring

- To ensure proper control (CTRL) cable connection between IQ System Controller 3 INT and IQ Batteries follow the guidelines outlined below while connecting the cable to the headers.

**WARNING!** Failure to follow wiring guidance will result in the system being unable to detect devices leading to commissioning and operation failures.

**NOTE:** To avoid mis-wiring note the wire color as well as the number on the wire cores. The figure alongside and the table below show the mapping of terminals on the header to the wire color and number on wire core.

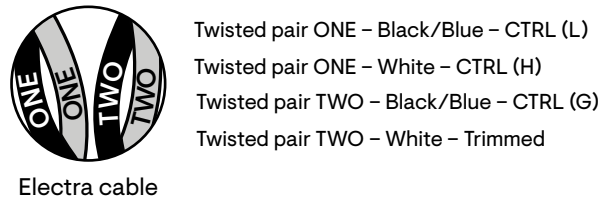
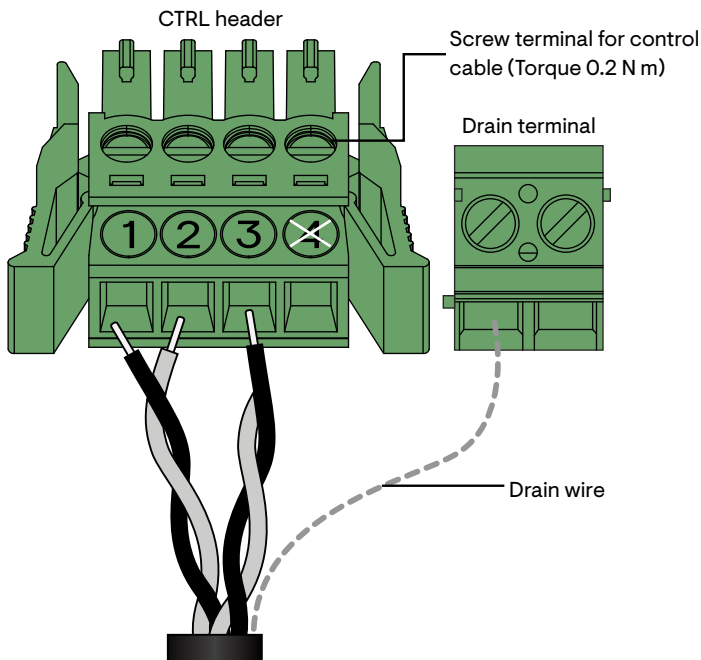

- Ensure that both ends of the CTRL cable twisted pair wires are inserted into the header as shown above. Confirm this by performing a continuity check between CTRL header screw terminals on both ends of the CTRL cable section.
- Connect drain wire to the drain terminal only at one end of a CTRL cable. Do not connect drain wires at both ends of a CTRL cable. Please follow guidance based on [Control \(CTRL\) wiring between system components](#) section.

**TIP:** Before pulling the cable through the conduit perform continuity checks and label each end of all the wires with small colored clips or stickers (with the same numerals as on the headers). This will enable easy identification of wires and avoid mis-wiring.

The table below provides mapping of the header numbers, control communication signals and twisted pair wire designation for Electra EAS7302PHV/EAS7502PHV and LAPP 1270802 cables:

CTRL HEADER NUMBERS	CTRL SIGNALS	ELECTRA WIRE DESIGNATION	LAPP WIRE DESIGNATION
Screw terminal 1	CTRL L	Twisted pair ONE - Black/Blue	Twisted pair 1 - Black
Screw terminal 2	CTRL H	Twisted pair ONE - White	Twisted pair 1 - White
Screw terminal 3	CTRL G	Twisted pair TWO - Black/Blue	Twisted pair 2 - Black
Screw terminal 4 (DO NOT USE)	NA	Twisted pair TWO - White (trimmed)	Twisted pair 2 - White (trimmed)

## Section B - Wiring

# Control (CTRL) wiring between system components

Control wiring guidance for the Enphase Energy System:

Refer to the following wiring sequences to understand the position of header with termination resistor, wiring order, and drain wire termination location.

**NOTE:** Ensure following guidelines are followed to avoid failures during system commissioning:

- One header with termination resistor should be installed on each component that is at the extreme end of the control network.

- The drain wire should only be terminated on one end of control wiring between system components
- It is recommended to terminate drain wire at the component from which the control wiring for the section is initiated
- Same conduits can be used for power and control wire routing with Enphase recommended cables

Following are three indicative wiring sequences:

**Sequence 1:** IQ System Controller 3 INT → IQ Battery(s) 5P

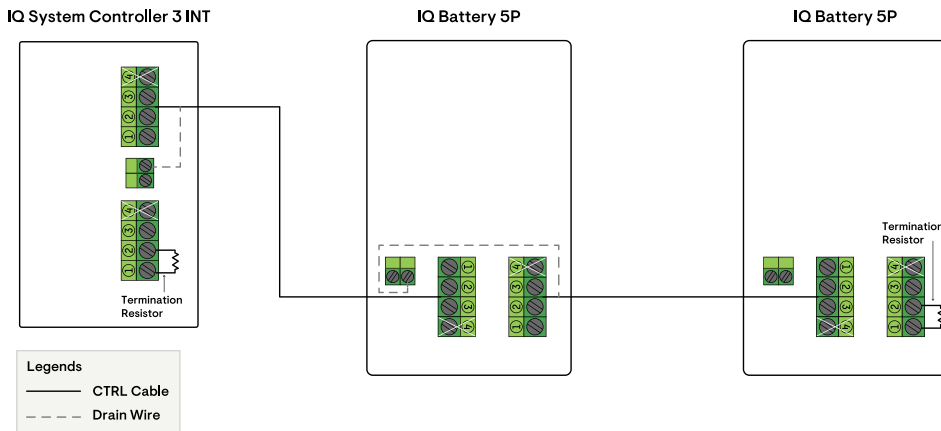

**NOTE:** Total length of CTRL wiring across the system cannot exceed 75 meters to ensure system operates as per specifications.

**Sequence 2:** IQ Battery(s) 5P → IQ System Controller 3 INT

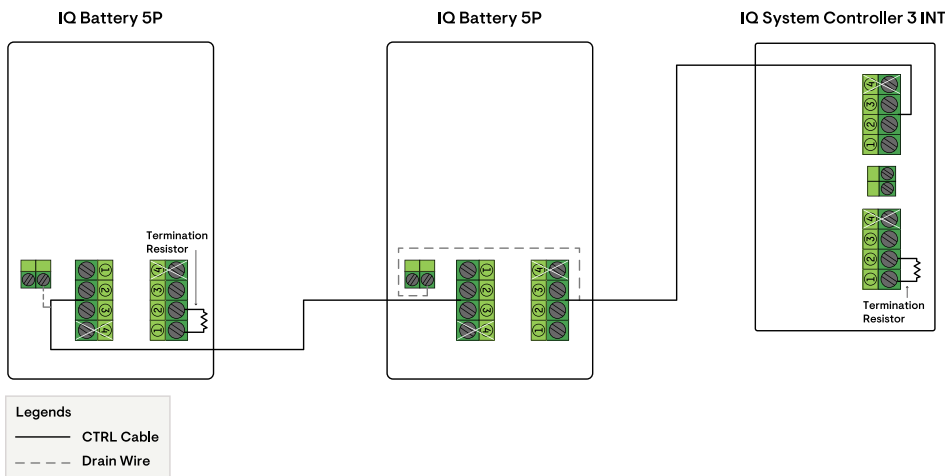

**NOTE:** Total length of CTRL wiring across the system cannot exceed 75 meters to ensure system operates as per specifications.

## Section B - Wiring

### Sequence 3: IQ Battery(s) 5P → IQ System Controller 3 INT → IQ Battery(s) 5P

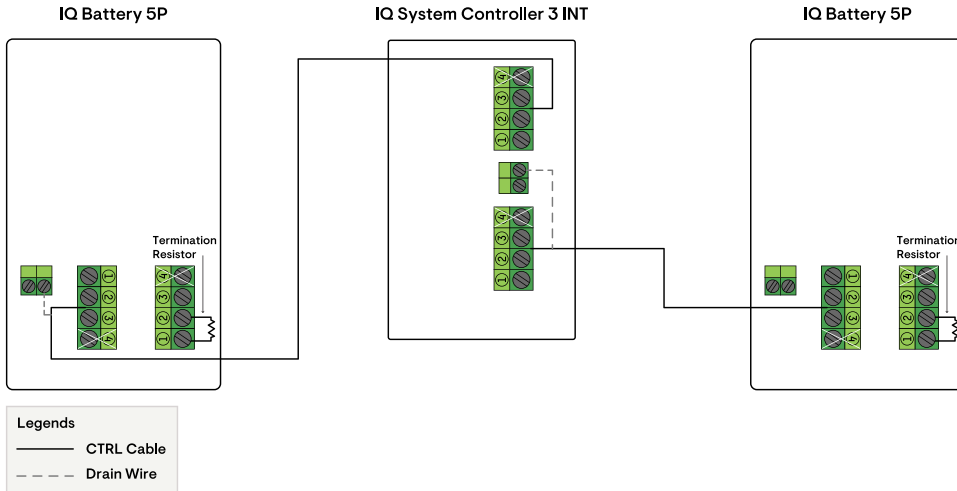

✓ **NOTE:** Total length of CTRL wiring across the system cannot exceed 75 meters to ensure system operates as per specifications.

Here is a table providing termination resistor locations for the above sequences:

CONTROL WIRING SEQUENCE	TERMINATION RESISTOR LOCATION
IQ System Controller 3 INT → IQ Battery(s) 5P	<ul style="list-style-type: none"> <li>• IQ System Controller 3 INT</li> <li>• Last IQ Battery 5P in the battery daisy chain</li> </ul>
IQ Battery(s) 5P → IQ System Controller 3 INT	<ul style="list-style-type: none"> <li>• First IQ Battery 5P in the battery daisy chain</li> <li>• IQ System Controller 3 INT</li> </ul>
IQ Battery(s) 5P → IQ System Controller 3 INT → IQ Battery(s) 5P	<ul style="list-style-type: none"> <li>• First IQ Battery 5P</li> <li>• Last IQ Battery 5P</li> </ul>

# Close dead front and install breaker filler plate

**WARNING!** Before energizing, make sure that all IQ System Controller 3 INT connections are properly installed and conductors terminated.

- Reattach the dead front using the three screws and tighten them using a Phillips screwdriver number two.
- Attach the breaker filler plate to the bottom part of the mains breaker cutout as shown in the image below.

**WARNING!** Risk of equipment damage. Ensure that no conductors are pinched before replacing the cover.

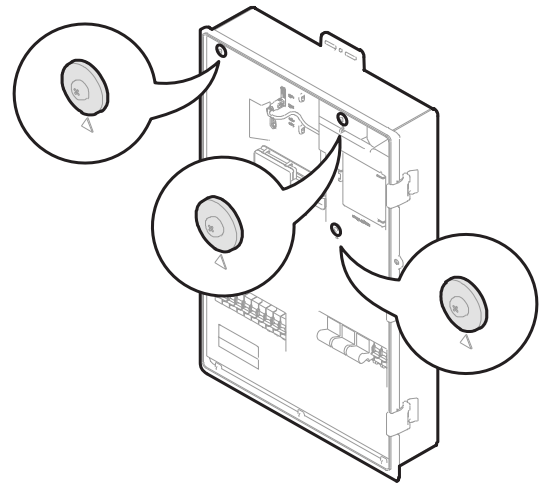
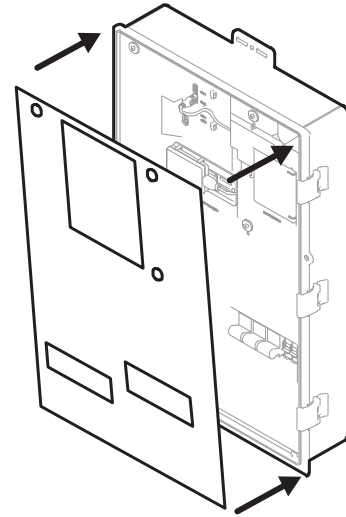
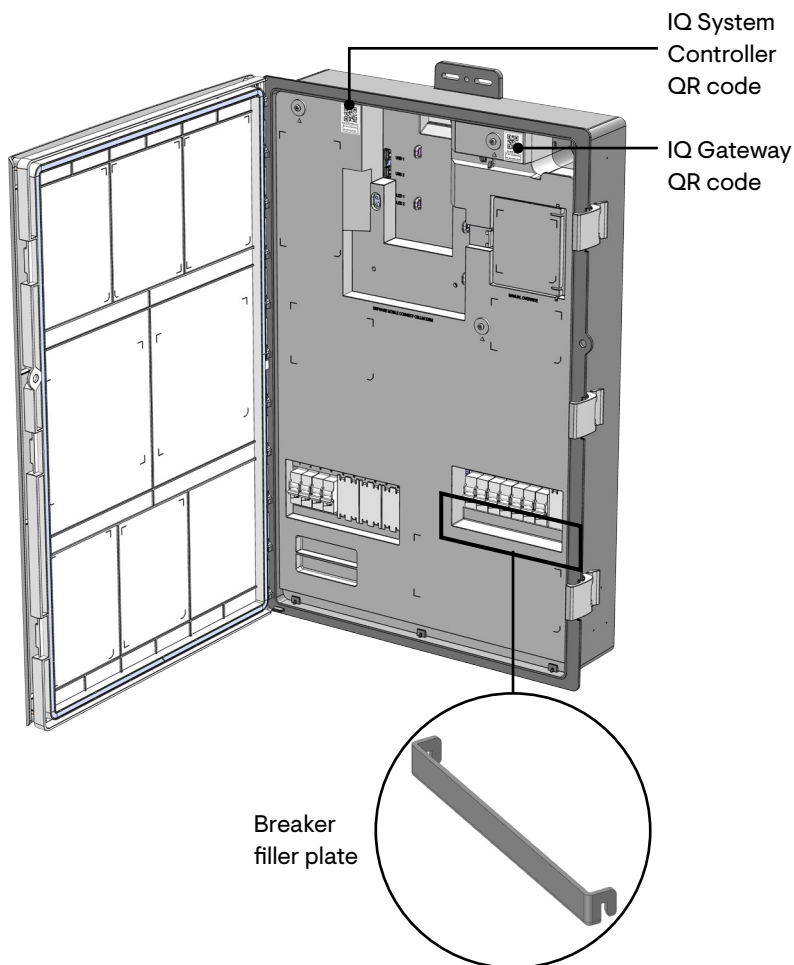

**NOTE:** Breakers for solar, IQ Battery, mains, and non-backup/backup loads are not supplied with IQ System Controller 3 INT and must be purchased separately. Breaker configurations shown in the above images are indicative.

# Connecting cellular modem

- ⊙ **NOTE:** The cellular connection is only intended as a backup. Primary internet connectivity must be provided using the homeowner's Ethernet/Wi-Fi. Cellular connectivity is subject to network operator coverage and signal strength.

The IQ System Controller 3 INT is packaged with the Mobile Connect Cellular modem - CELLMODEM-M1-06-AT-05.

## Connecting the USB cable

1. Connect the USB cable to the USB port(s) on the IQ System Controller.
2. Connect the cable to the USB port of Cellular modem.

## Checking the Cellular modem status LEDs

The modem has the following status LEDs

- Power
- Link
- Signal

The LEDs are located on the upper right side of the front panel, as shown in the below diagram:

The Power LED turns green when the modem is powered. After a few minutes, the Link status LED on the Cellular modem flashes to indicate a network connection. The Signal LEDs indicate signal strength as shown in the table on the next page.

No additional configuration is needed.

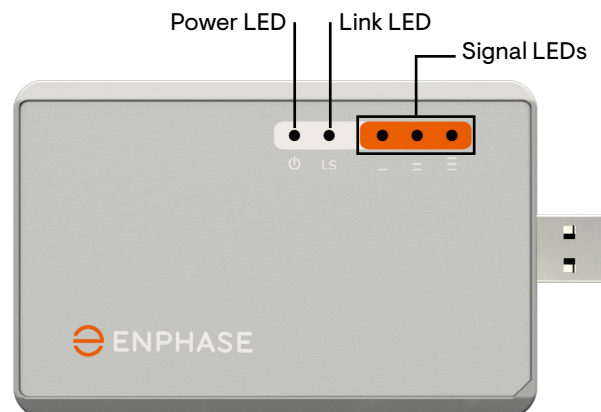

## Check connection status and cellular signal strength





When the IQ System Controller establishes an internet connection, the IQ Gateway Network Communications LED is solid green. You can use the Enphase Installer App to check the modem status and cellular signal strength. The IQ Gateway's AP (Access Point) Wi-Fi network allows you to connect your mobile device (smartphone or tablet) to the IQ Gateway.

1. On the IQ Gateway, the AP Mode LED is solid green when the AP mode is active. If the AP Mode LED is not lit, press the AP Mode button.
2. Launch Enphase Installer App and tap connect to IQ Gateway.
3. Tap Network.
4. Under Network Configuration, tap Cellular. The app displays connection status and an indication of signal strength.
5. Check the connection status and verify that signal strength is at least two bars for adequate data transmission.

### LED status:

POWER LED	INDICATES
Off	DC power via USB not present
On	DC power via USB present

LINK LED	INDICATES
Flashing slowly (200 ms high/1,800 ms low)	Searching for available network
Flashing slowly (1,800 ms high/200 ms low)	Idle
Flashing quickly (125 ms high/125 ms low)	Data transfer in progress

SIGNAL LEDs	DESCRIPTION	INDICATES
	All OFF	Very weak signal
	Bar 1 ON	Weak signal
	Bar 1 and 2 ON	Good signal
	Bar 1, 2, and 3 ON	Very good signal

### Troubleshooting:

ISSUE	ACTION
No communication with Enphase App after connecting the Cellular modem to the IQ Gateway.	<ol style="list-style-type: none"> <li>1. Disconnect the USB cable.</li> <li>2. Reboot the IQ Gateway using the Enphase App or the Enphase Installer App</li> <li>3. Wait until the IQ Gateway boots completely.</li> <li>4. Reconnect the Cellular modem USB cable.</li> </ol>
I want to disconnect the modem and reuse it at a different site.	Moving the modem to a different IQ Gateway deactivates the modem. Contact Enphase Customer Support if you need to reinstall the modem at a different site.

# System Shutdown (SSD) switch wiring

**⚠ WARNING!** Risk of equipment damage. Do not wire the IQ System Controller 3 INT when it is energized.

Any system using the IQ System Controller 3 INT requires a system shutdown (SSD) switch. The SSD switch when used in conjunction with PV and battery breakers disconnect all PV panels and battery from the home to ensure the safety of maintenance technicians. When the system shutdown sequence outlined in this section is followed, the Enphase Energy System will be shutdown and the home is connected to the grid.

The SSD switch is a double pole single throw lockable switch. The SSD switch should be placed in a readily accessible location outdoor and wired to IQ System Controller 3 INT. The maximum distance between the SSD switch and IQ System Controller is 60 meters.

The SSD port in IQ System Controller 3 INT uses a detachable header that must be wired to the SSD switch. By default, the header is shorted. You must remove the wires shorting the header and connect the wires from the SSD switch.

Follow the instructions below while SSD switch installation:

- Open the front face of the SSD enclosure by loosening the four screws on the front face.
- Create wiring conduit in the top/bottom portion of the enclosure. There are knock outs provided for this.
- Use wires of cross section 0.5-1.5 sq. mm. to connect SSD switch to header.
- Draw the wires out through the conduit which has been created in the enclosure.

- Use 1.2 N m torque to connect wires to SSD switch.
- Use appropriately sized ferrule to terminate the wire in the header.
- Use 0.2 N m torque to connect the wire to header.
- Wire the terminal 1 and terminal 5 of SSD switch to pin 1 and 2 of the header respectively.
- Wire the terminal 6 and terminal 2 of SSD switch to pin 3 and 4 of the header respectively.
- Terminal 3 and 4 of the SSD switch are not to be used.
- Secure the switch to the rear plate of the enclosure using push-fit latches.
- There are 4 mounting points on the back plate of the enclosure to mount the SSD switch enclosure.
- The type of screw is to be determined by installer based on the SSD switch mounting location.
- Use 1.0 N m torque to secure the front cover to the back plate of the enclosure.
- Ensure that the switch is in "ON" position.
- Plug the header on to the IOB board.

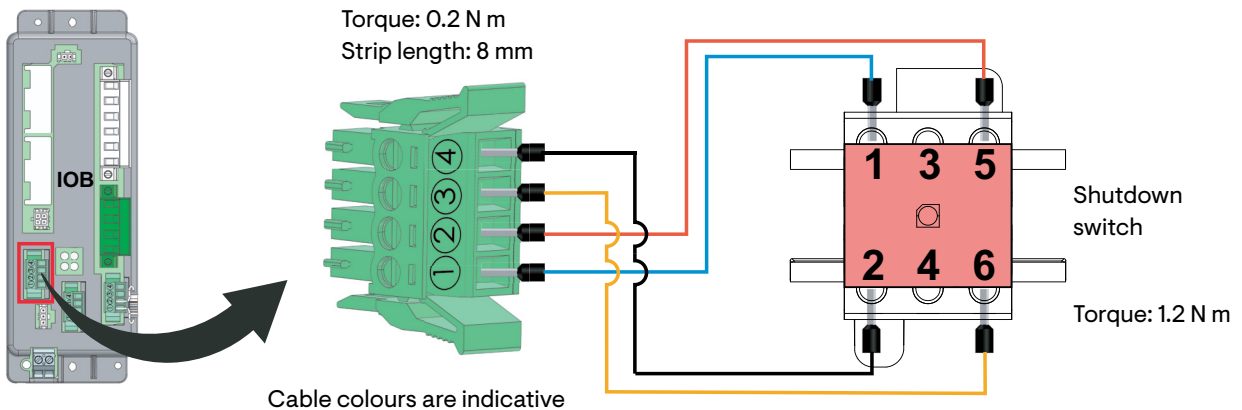



## Steps to activate System Shutdown

1. Turn the SSD switch to the “OFF” position.
2. Press the DC switches on all IQ Battery 5P units to turn them “OFF”
3. Turn the PV breakers in the IQ System Controller 3 INT to “OFF” position.
4. Turn the IQ Battery 5P breakers in IQ System Controller 3 INT to “OFF” position.

## Steps to de-activate System Shutdown

1. Turn the SSD switch to the “ON” position.
2. Turn the PV breakers in the IQ System Controller 3 INT to “ON” position.
3. Turn the IQ Battery 5P breakers in IQ System Controller 3 INT to “ON” position.
4. Press the DC switch on all IQ Battery 5P units to turn them “ON”

### SSD header-switch wiring sequence:

SSD HEADER PIN	SSD SWITCH TERMINAL
Pin-1	Terminal-1
Pin-2	Terminal-5
Pin-3	Terminal-6
Pin-4	Terminal-2

# Energize IQ System Controller 3 INT



**DANGER:** Risk of electric shock. There are many potential sources of voltage. Check any IQ Battery, PV, or other generation source for voltage.



**WARNING!** Risk of equipment damage. Do not wire the IQ System Controller 3 INT when it is energized.

- A. You must ensure that all electrical circuits external to IQ System Controller 3 INT are completed, safely terminated, and connected to the correct phase and neutral connection before energizing the IQ System Controller 3 INT.



**NOTE:** If you are not commissioning the system, you must ensure that the DC switches on all IQ Batteries are turned off to avoid the depletion of charge on the IQ Batteries.

- B. If you plan to commission the system, follow the instructions in the Enphase Installer App for energizing the IQ System Controller 3 INT.
- C. Energize the circuit feeding the IQ System Controller 3 INT. If installed, turn the breaker feeding the IQ System Controller 3 INT to the ON position.
- Turn on the SSD switch
  - Turn on mains breaker
  - Turn on backup and non backup loads breaker
  - Turn on PV breakers
  - Turn on battery breaker
  - Turn on the DC switch on each IQ Battery
- D. Close and secure the dead front and door of the IQ System Controller 3 INT.

## Configure and activate

- Use the Enphase Installer App to commission the IQ System Controller 3 INT.
- If you do not see the IQ System Controller 3 INT information in Enphase Installer App, check that the IQ Gateway AP mode light is green. If not, press the AP mode button and follow the instructions in Enphase Installer App to connect the phone to the IQ Gateway's Wi-Fi network.
- Once connected to the IQ Gateway, refer to the Enphase Installer App help topics for more information.

## Manual override mode

In the event of an emergency, follow the instructions on the manual override switch cover to enable or disable manual override mode. By enabling manual override mode, your system will bypass the IQ Batteries and PV, and your system will become grid-tied. You should only perform these steps in the event of an emergency or if you've been instructed to do so by Enphase support.

# Safety

**IMPORTANT SAFETY INSTRUCTIONS. SAVE THESE INSTRUCTIONS.** This guide contains important instructions that you must follow during installation and maintenance of the IQ System Controller 3 INT. Failing to follow any of these instructions may void the warranty ([enphase.com/warranty](http://enphase.com/warranty)).

## In Case of Fire or Other Emergency

### In all cases:

- If safe to do so, turn off all DC switches on each IQ Battery.
- Turn off PV breaker and battery breakers inside the IQ System Controller 3 INT.
- Turn off the AC breaker for the IQ System Controller 3 INT circuit.
- If an isolator switch is present, switch off the AC isolator for the IQ System Controller 3 INT circuit.
- Contact the fire department or other required emergency response team.
- Evacuate the area.

### In case of fire:

- When safe, use a fire extinguisher. Suitable types are A, B, and C dry chemical fire extinguishers. Additional extinguishing media include carbon dioxide or alcohol-resistant foams.



### In case of flooding:

- Stay out of water if any part of the IQ System Controller 3 INT or wiring is submerged.
- If possible, protect the system by finding and stopping the source of the water, and pumping it away.
- If water has contacted the unit, call your installer to arrange an inspection. If you are sure that water has never contacted the battery, let the area dry completely before use.







### In case of unusual noise, smell or smoke:















- Ensure nothing is in contact with the IQ System Controller 3 INT.
- Ventilate the room.
- Contact Enphase Customer Support at [enphase.com/en-us/support/contact](http://enphase.com/en-us/support/contact).

## Safety and Advisory Symbols

-  **DANGER:** This indicates a hazardous situation, which if not avoided, will result in death or serious injury.
-  **WARNING:** This indicates a situation where failure to follow instructions may be a safety hazard or cause equipment malfunction. Use extreme caution and follow instructions carefully.
-  **NOTE:** This indicates information particularly important for optimal system operation. Follow instructions carefully.

## Safety Instructions

-  **DANGER:** Risk of electric shock. Risk of fire. Only qualified electricians should install, troubleshoot, or replace the IQ System Controller 3 INT.
-  **DANGER:** Risk of electric shock. Risk of fire. Do not attempt to repair the IQ System Controller 3 INT. Tampering with or opening the IQ System Controller 3 INT will void the warranty. If the IQ System Controller 3 INT fails, contact Enphase Customer Support for assistance at [enphase.com/en-us/support/contact](http://enphase.com/en-us/support/contact).
-  **DANGER:** Risk of electric shock. Do not use Enphase equipment in a manner not specified by the manufacturer. Doing so may cause death or injury to persons, or damage to equipment.
-  **DANGER:** Risk of electric shock. Do not install the IQ System Controller 3 INT without first removing AC power from the photovoltaic system and ensuring that the DC switch on the IQ Batteries are off. Disconnect the power coming from the photovoltaics and ensure that the DC switch on the IQ Batteries are off before servicing or installing.
-  **DANGER:** Risk of electric shock. Risk of fire. Do not work alone. Someone should be in the range of your voice or close enough to come to your aid when you work with or near electrical equipment.
-  **DANGER:** Risk of fire. Do not allow or place flammable, sparking, or explosive items near the IQ System Controller 3 INT.
-  **DANGER:** Risk of electric shock. In areas where flooding is possible, install the IQ System Controller 3 INT at a height that prevents water ingress.

-  **WARNING:** Risk of equipment damage. IQ System Controller 3 INT is shipped and stored on its back. The upright position is only needed when installed.
-  **WARNING:** You must install the IQ System Controller 3 INT only on a suitable wall using appropriate hardware.
-  **WARNING:** Before installing or using the IQ System Controller 3 INT, read all instructions and cautionary markings in this guide and on the equipment.
-  **WARNING:** Do not install or use the IQ System Controller 3 INT if it has been damaged in any way.
-  **WARNING:** Do not sit on, step on, place objects on, or insert objects into the IQ System Controller 3 INT.
-  **WARNING:** Do not place beverages or liquid containers on top of the IQ System Controller 3 INT. Do not expose the IQ System Controller 3 INT to flooding.
-  **NOTE:** Perform installation and wiring, including protection against lightning and resulting voltage surge, in accordance with all applicable local electrical codes and standards.
-  **NOTE:** Using unapproved attachments or accessories could result in damage or injury.
-  **NOTE:** Install properly rated over current protection as part of the system installation as per local standards and regulations.
-  **NOTE:** To ensure optimal reliability and to meet warranty requirements, the IQ System Controller 3 INT must be installed and/or stored according to the instructions in this guide and adhering to local standards and regulations.
-  **NOTE:** The IQ System Controller 3 INT is intended to operate with an internet connection through the built-in IQ Gateway. Failure to maintain an internet connection may have an impact on the warranty. See limited warranty for full terms and services ([enphase.com/warranty](http://enphase.com/warranty)).
-  **NOTE:** When replacing an IQ System Controller 3 INT, you must replace it with an IQ System Controller 3 INT of the same type, with the same AC current rating.
-  **NOTE:** Properly mount the IQ System Controller 3 INT. Ensure that the mounting location is structurally suited to bearing the weight of the IQ System Controller 3 INT.
-  **NOTE:** During use, storage, and transport, keep the IQ System Controller 3 INT:
  - Properly ventilated
  - Away from water, other liquids, heat, sparks, and direct sunlight
  - Away from excessive dust, corrosive and explosive gases, and oil smoke
  - Away from direct exposure to gas exhaust, such as from motor vehicles
  - Away from falling or moving objects, including motor vehicles. If mounted in the path of a motor vehicle, we recommend a 91cm (36-inch) minimum mounting height
  - In a location compliant with fire safety regulations
  - In a location compliant with local building codes and standards

## Safety Warnings

 **WARNING:** This cellular device may cause interference with other electronic equipment if the equipment is inadequately protected.

 **WARNING:** Follow restrictions imposed for any environment in which the device may operate, such as fuel depots, chemical plants, or where blasting operations are in process.

## Potential interference with pacemakers and other medical devices

Radio frequency energy (RF) from cellular devices can interact with some electronic devices, causing electromagnetic interference (EMI). The FDA helped develop a detailed test method to measure EMI of implanted cardiac pacemakers and defibrillators from cellular devices. This test method is part of the Association for the Advancement of Medical Instrumentation (AAMI) standard. This standard allows manufacturers to ensure that cardiac pacemakers and defibrillators are safe from cellular device EMI. The FDA continues to monitor cellular devices for interactions with other medical devices. If harmful interference occurs, the FDA will assess the interference and work to resolve the problem.

## Precautions for pacemaker wearers

EMI can affect a pacemaker in one of three ways:

- Stop the pacemaker from delivering the stimulating pulses that regulate the heart's rhythm.
- Cause the pacemaker to deliver the pulses irregularly.
- Cause the pacemaker to ignore the heart's own rhythm and deliver pulses at a fixed rate.

Based on current research, cellular devices do not pose a significant health problem for most pacemaker wearers. However, people with pacemakers may want to take simple precautions to avoid EMI from cellular devices:

- Keep the device on the opposite side of the body from the pacemaker to add extra distance between the pacemaker and the device.
- Avoid placing a turned-on device next to the pacemaker (for example, don't carry the device in a shirt or jacket pocket directly over the pacemaker).

## Cellular modem Terms and conditions

These following Cellular modem Terms and Conditions ("Terms and Conditions") will apply to anyone who purchases and/or uses ("you", "your") the Cellular modem to enable internet connectivity for an IQ Gateway device ("Cellular modem Terms"). These Cellular modem Terms are incorporated into and made an integral part of the Agreement.

1. **Cellular modem description, use, unauthorized use limitation on use.** The Cellular modem must be used only in conjunction with Enphase's IQ Gateway/IQ Combiner products. The Cellular modem shall not be used for any unlawful purpose(s).
2. **Limited Warranty.** The Cellular modem comes with and is covered by a 5-year Limited Warranty which is included in the standard Enphase Limited Warranty which can be found at [www.enphase.com/warranty](http://www.enphase.com/warranty) ("Limited Warranty"). Except as expressly provided in this Section, to the maximum extent permitted by applicable law, the Cellular modem is provided on an "AS IS" basis without warranty whatsoever, and Enphase expressly disclaims all warranties, express, implied, and statutory including the implied warranties of merchantability, satisfactory quality, fitness for a particular purpose, title, and non-infringement. Any use of the Cellular modem other than as expressly stated in these Terms and Conditions shall constitute a breach of the limited warranty and render it null and void. The Cellular modem will contain a SIM card provided by a network provider. The SIM card (a) must not be removed from the Cellular modem, nor (b) used with any other device. Any such removal or use shall constitute a breach of the Limited Warranty and render the Limited Warranty null and void.

3. **Territory.** The Cellular modem shall only be used in the countries listed on this quick installation guide (QIG). Enphase in its sole discretion reserves the right to amend the QIG to add or delete countries wherein the Cellular modem may be used.
4. **Network Coverage.** Network Coverage is dependent upon network availability which is the responsibility of the network service provider. **Enphase shall have no responsibility, nor any liability to any end user for network service provider's non-coverage, lack of coverage, defective coverage, or termination of the coverage.**
5. **Connectivity.** Cellular modem connectivity is subject to the telecommunication regulations and policies and terms of the network service providers, and the applicable laws of the country in which the Cellular modem is located and installed. **Enphase makes no representation or warranties as to such connectivity and Enphase shall have no responsibility, nor any liability to you for network service provider's failure to provide connectivity nor any responsibility or liability due to network service provider's termination of connectivity.**
6. **Acceptable Use Policy.** You must conform to the applicable acceptable use policy ("AUP") posted on the applicable network providers website, and you alone will be responsible for ensuring compliance with its terms. You will indemnify, defend and hold Enphase harmless against any claims or losses suffered by Enphase because of your breach of the AUP.

For Cellular modems with:

**AT&T connectivity** – The terms available at <https://www.att.com/legal/terms.aup.html> shall apply.

### Manufacturer:

Enphase Energy Inc.,  
47281 Bayside Pkwy.,  
Fremont, CA, 94538,  
The United States of America  
PH: +1 (707) 763-4784  
Assembled in China

### Importer:

Enphase Energy Aust. Pty/Ltd.,  
88 Market St.,  
South Melbourne VIC 3205.  
PH: +61 3 86691679



## Environmental Protection

**ELECTRONIC DEVICE: DO NOT THROW AWAY.** Waste electrical products should not be disposed of with household waste. Refer to your local codes for disposal requirements.

# Revision history

REVISION	DATE	DESCRIPTION
140-00273-06	May 2023	Added IQ Gateway breaker support. Added QR code. Added wiring detail for single-phase and three-phase homes.
140-00273-05	May 2023	Added details of breaker filler plate usage. Added wiring control (CTRL) cable to headers. Added control (CTRL) wiring between system components. Added Cellular modem support and associated safety page. Added page with system shutdown switch wiring instructions as well as steps to activate/de-activate system shutdown. Made minor corrections and grammatical corrections to content across QIG.
Previous releases		

# Installer notes

# Installer notes

IQSC-3-IG-0076-06-EN-INT-2023-05-19

© 2023 Enphase Energy. All rights reserved. Enphase, the e and CC logos, IQ, and certain other marks listed at <https://enphase.com/trademark-usage-guidelines> are trademarks of Enphase Energy, Inc. in the US and other countries. Data subject to change.

